

# Advances in Series-Compensated Line Protection

Joe Mooney

*POWER Engineers, Inc.*

Hector Altuve, George Alexander

*Schweitzer Engineering Laboratories, Inc.*

# Series Capacitors

- Improve power transfer
- Improve system stability
- Location of capacitor varies
- Dedicated protection
  - ◆ Spark gap
  - ◆ Metal-oxide varistor (MOV)

# Gap-Protected Bank

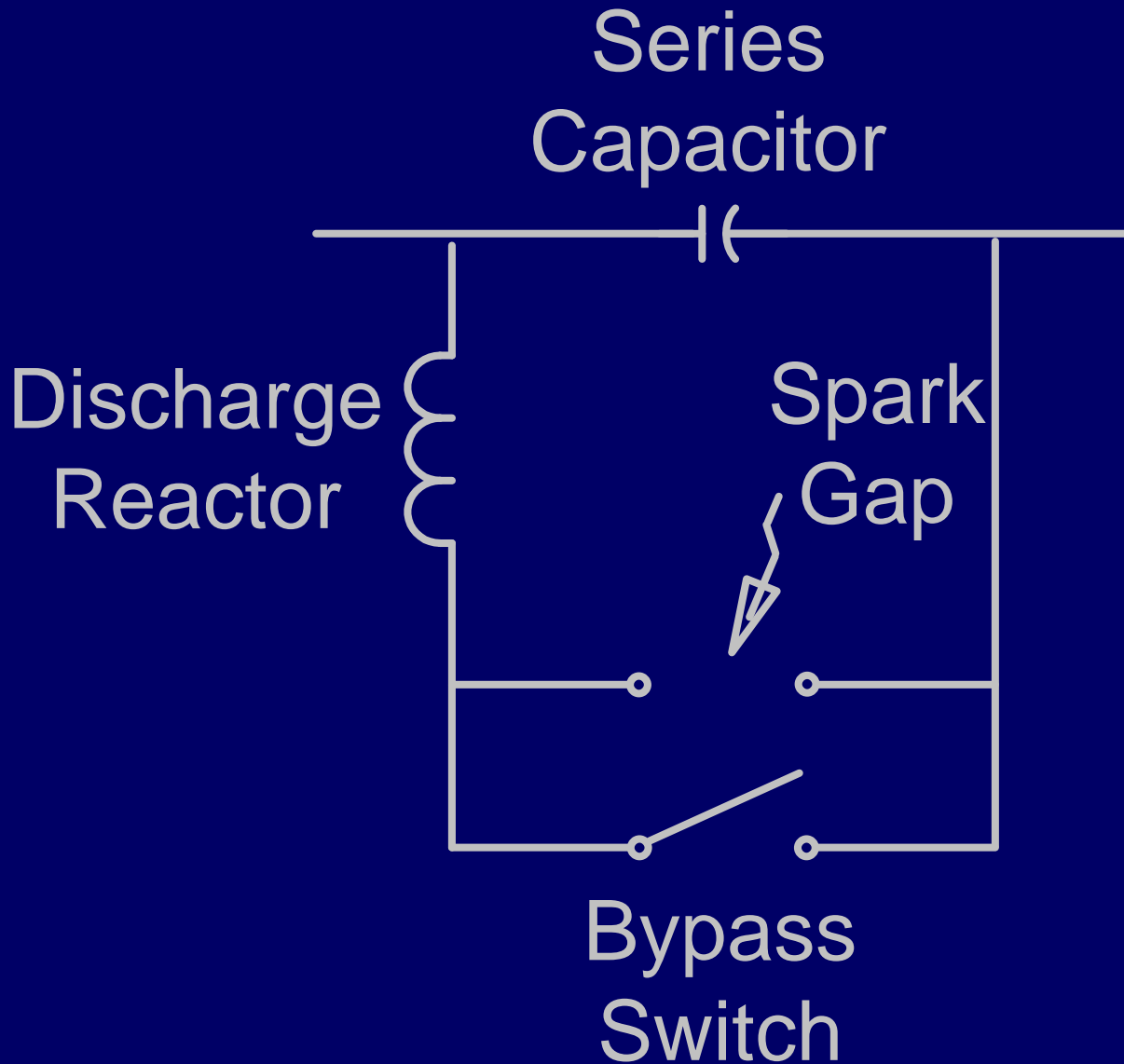

# MOV Protected Bank

Series Capacitor

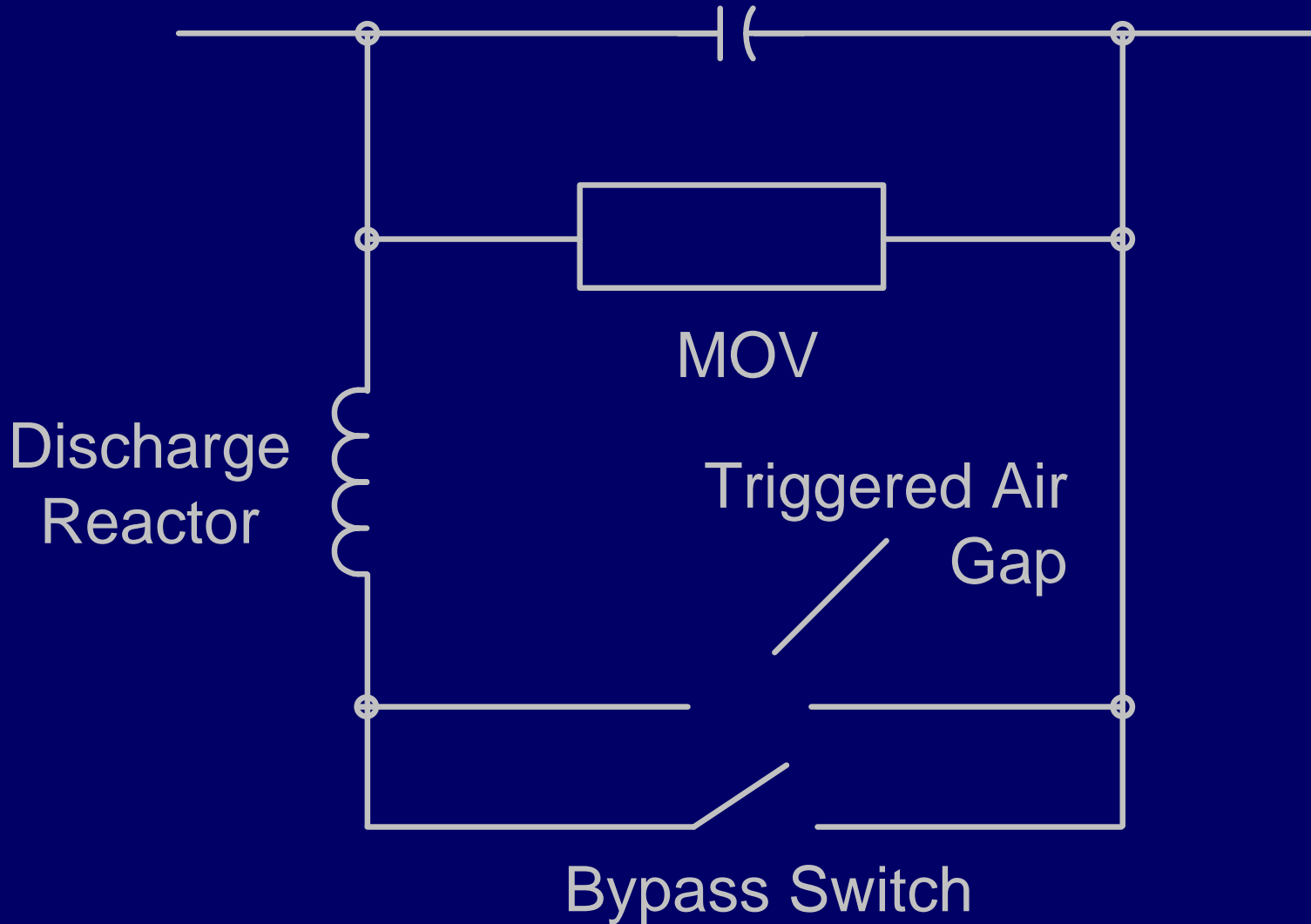

# Line Protection Challenges

- Voltage inversion
- Current inversion
- Directional security
- Reduced line impedance
- Low frequency resonance

# Voltage Inversion – Forward Fault

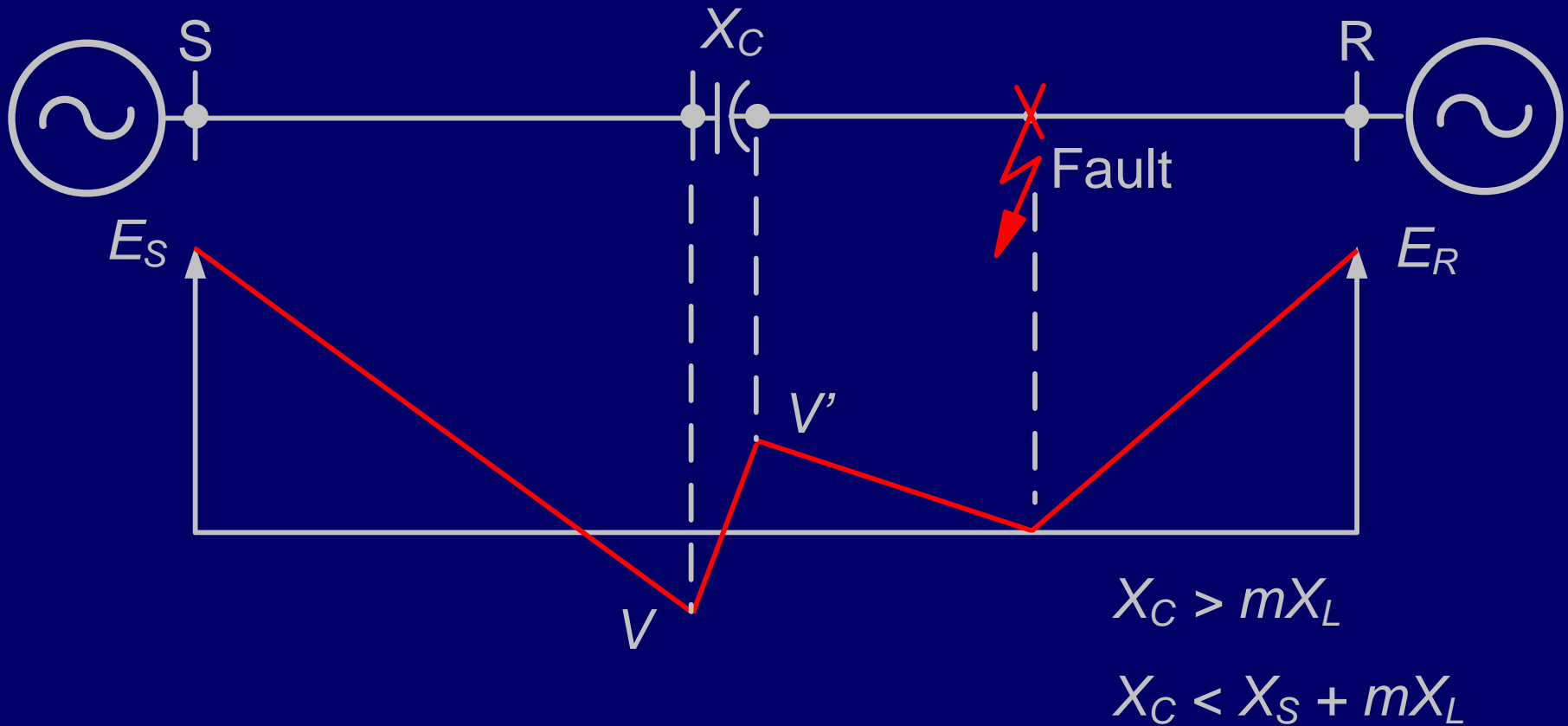

# Voltage Inversion – Reverse Fault

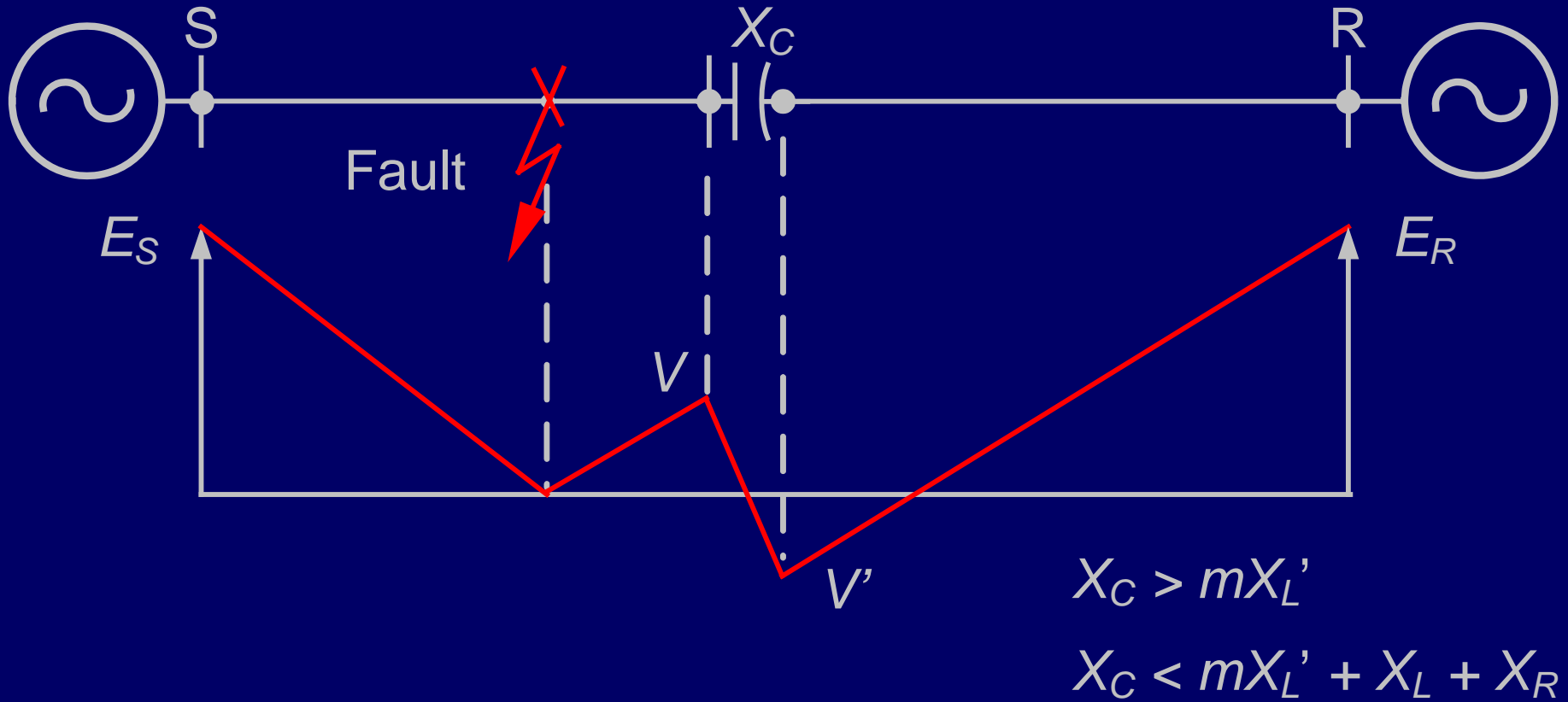

# Voltage Inversion – Negative-Sequence

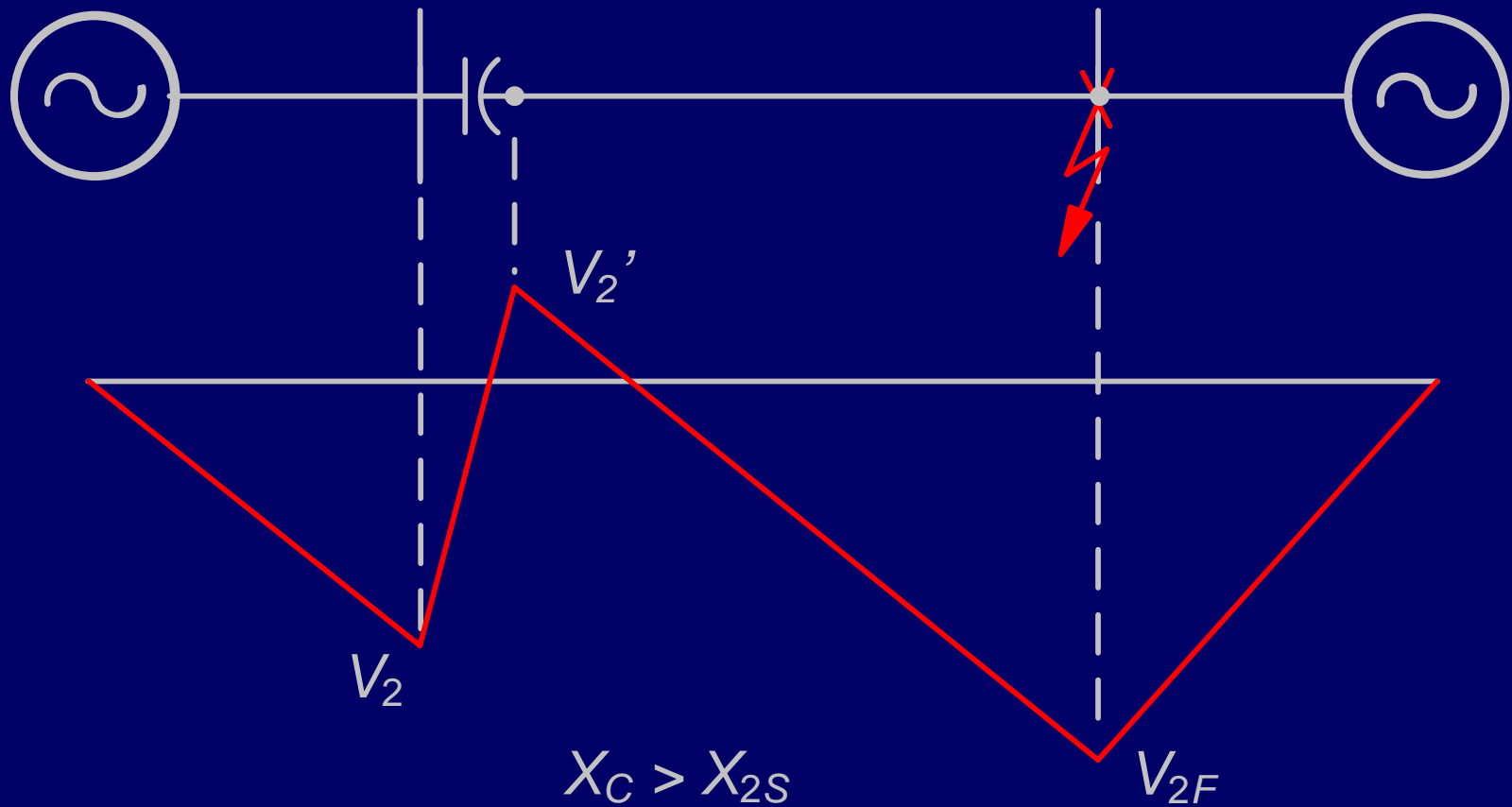

# Current Inversion



$$X_C > X_S$$



# Impedance Measurement – Mid-Line

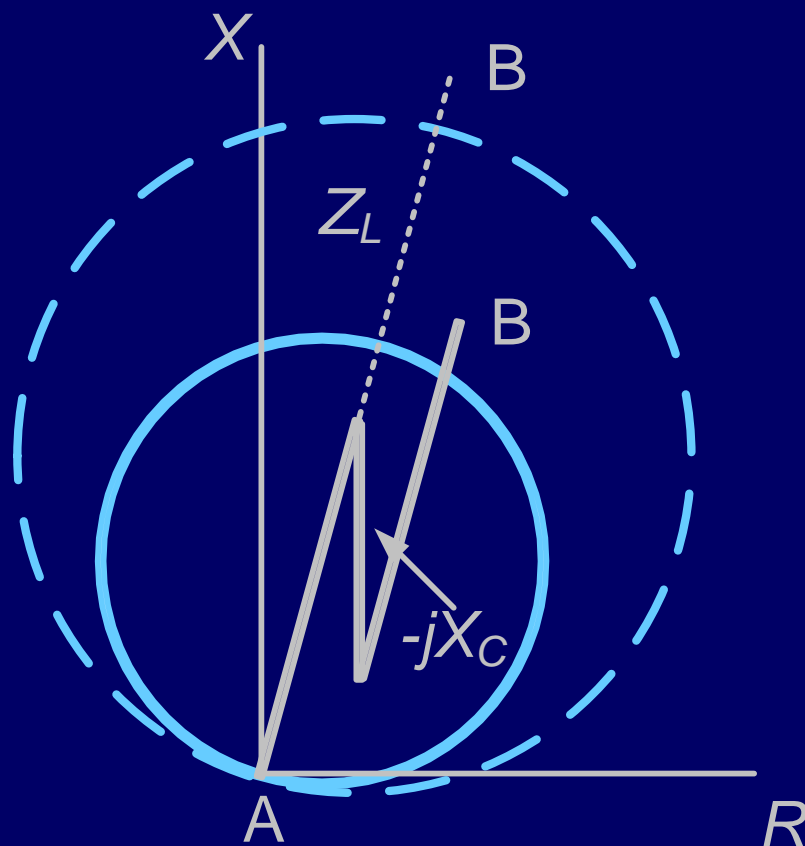
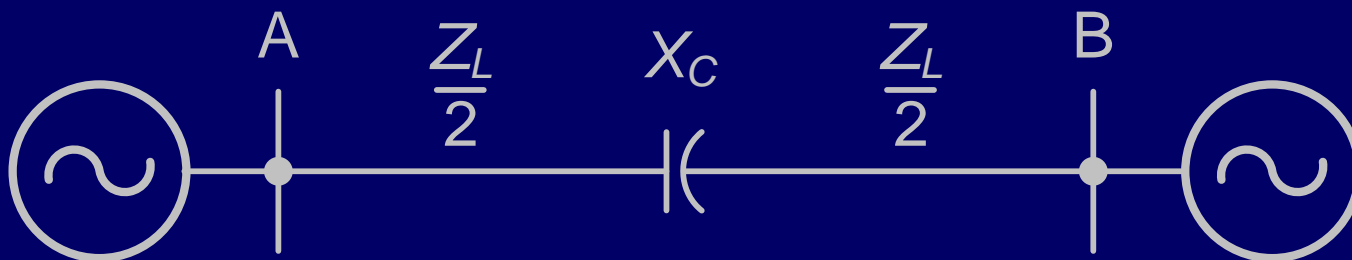

# Impedance Measurement – End-of-Line

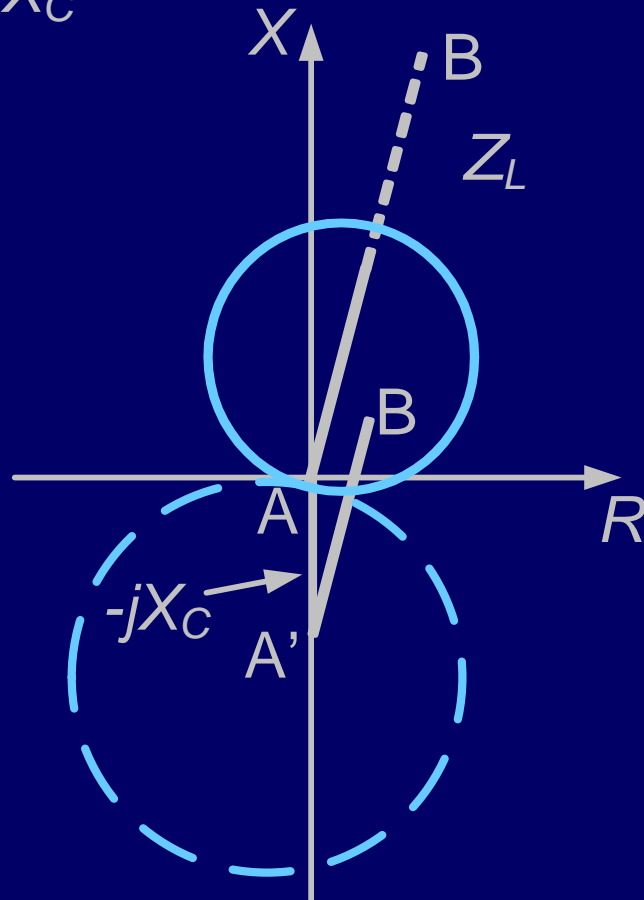
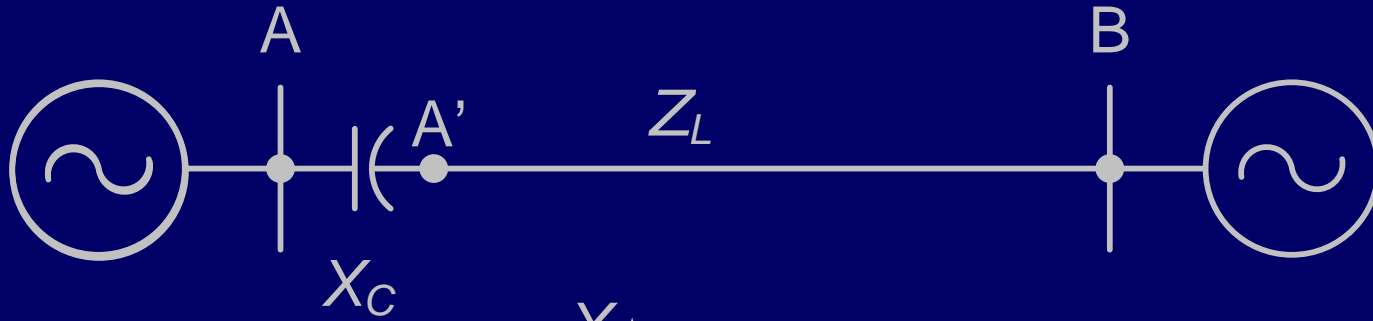

# Transient Response

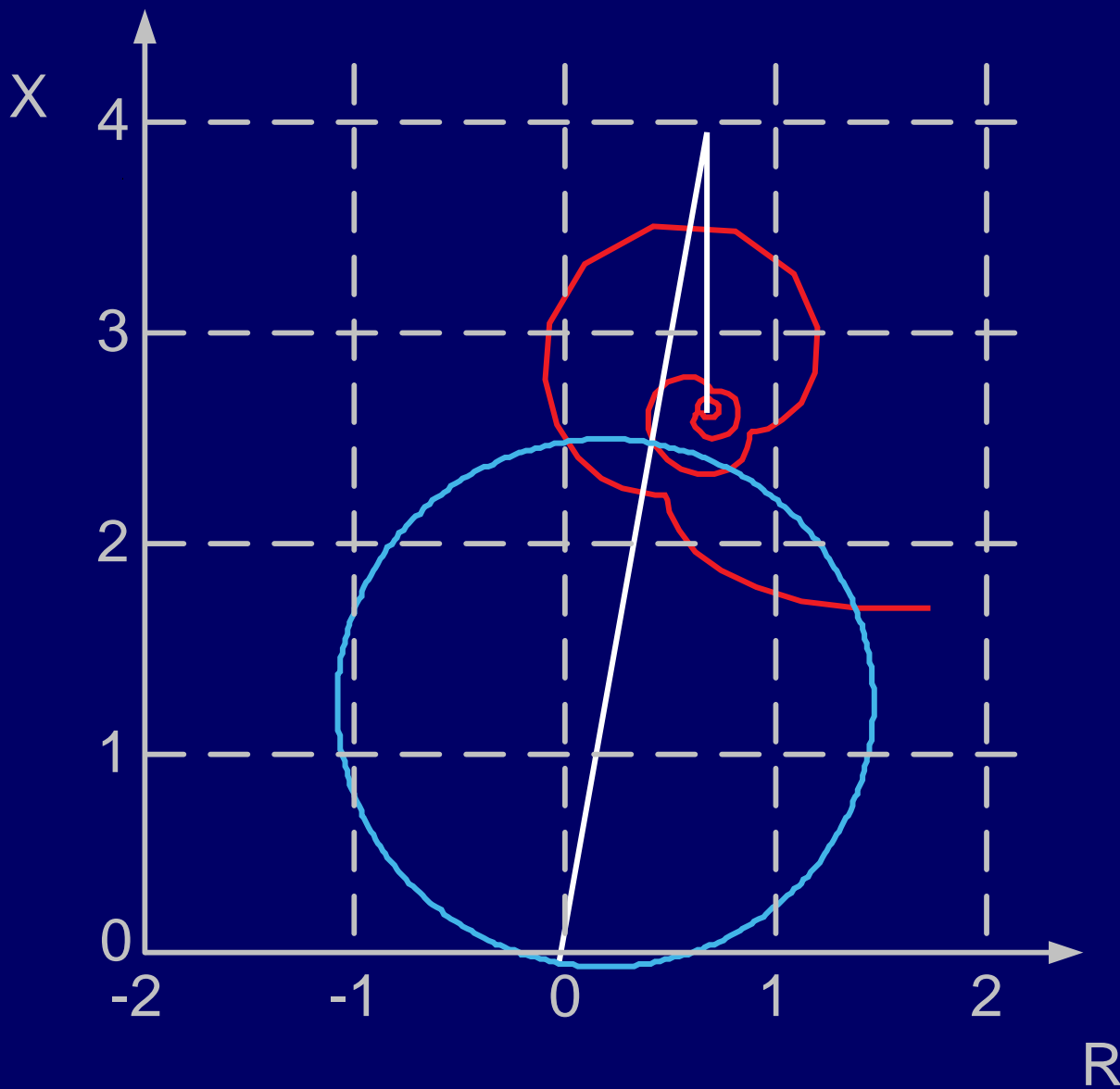

# Advancements and Solutions

- Memory polarization
- Directional element offset
- Overreach supervision
- Differential elements

# Mho Characteristic

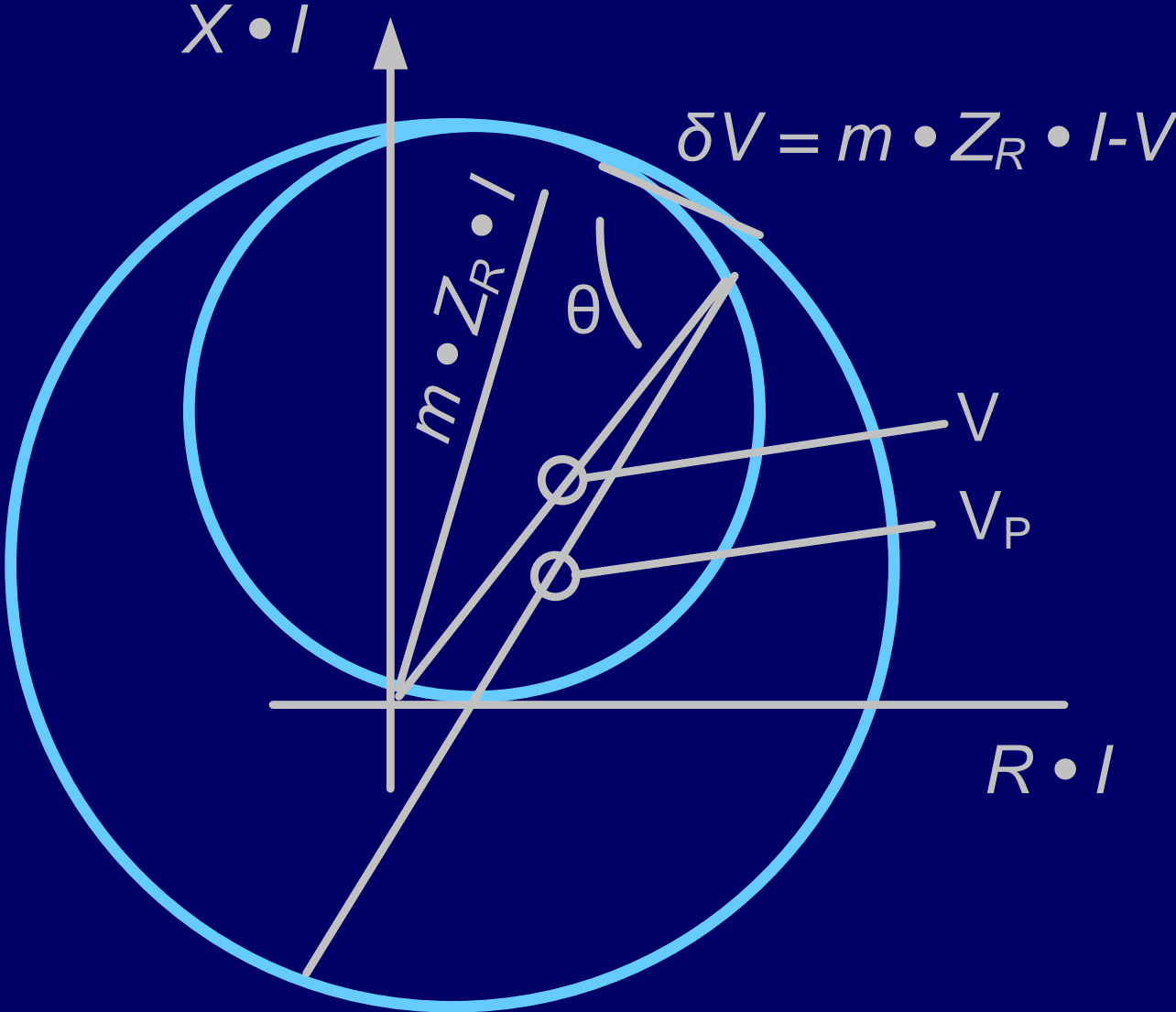

# Directional Element Characteristic

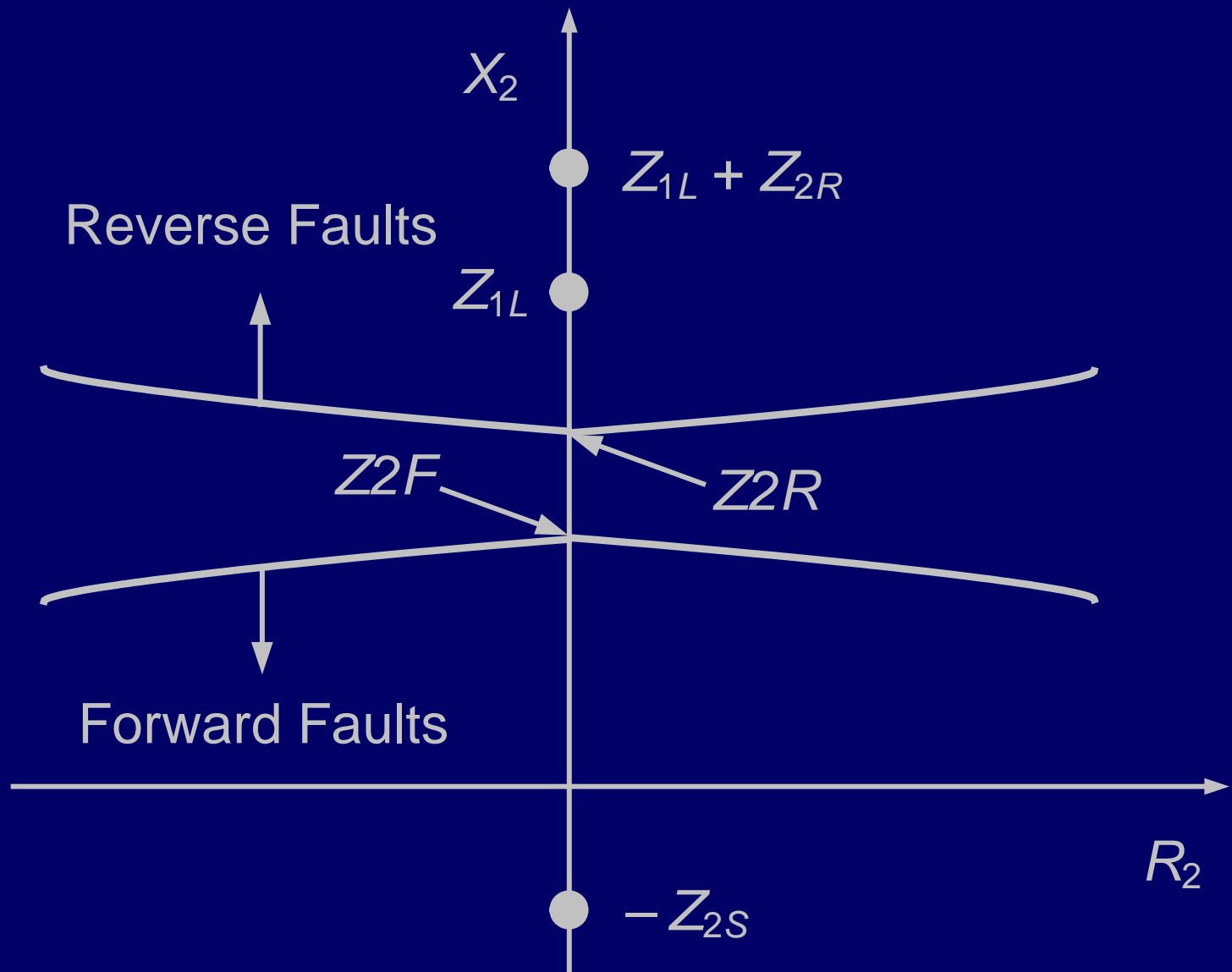

# Directional Element Offset Mid-Line Cap

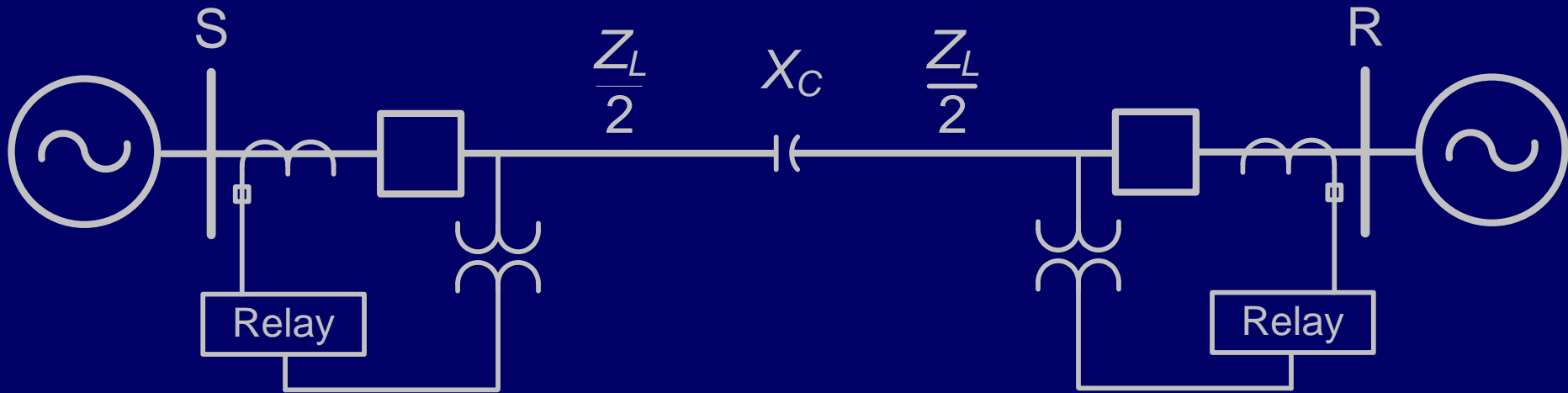

# Directional Element Offset

## End-of-Line Cap, Bus PT

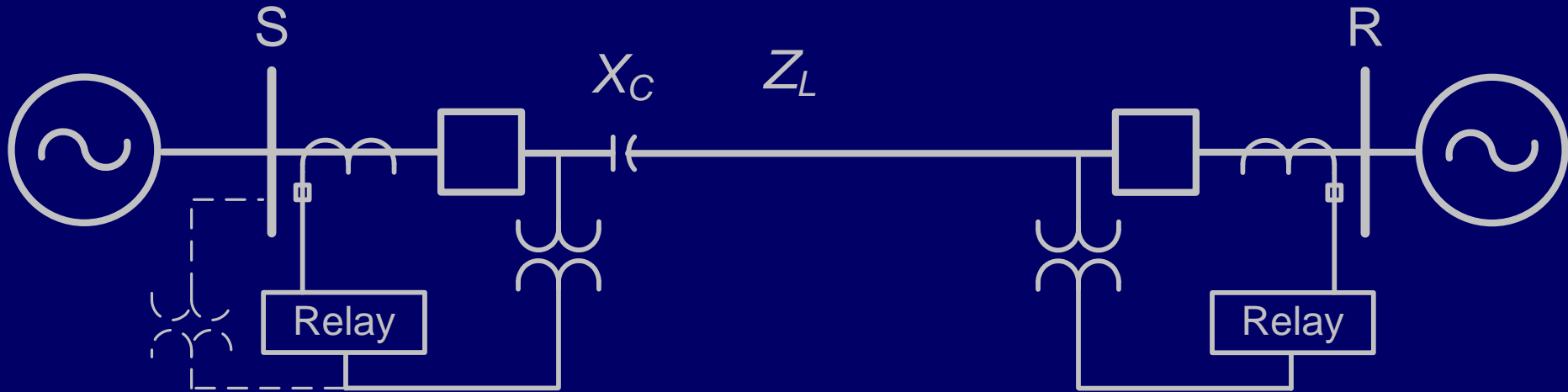

# Directional Element Offset

## End-of-Line Cap, Line Side PT

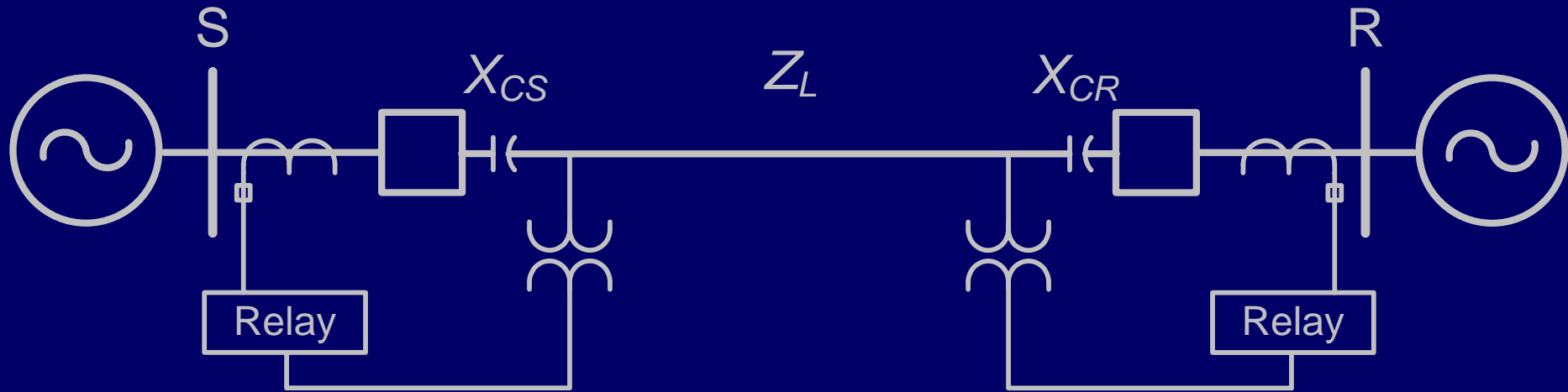

# Out-of-Section Fault Beyond Cap

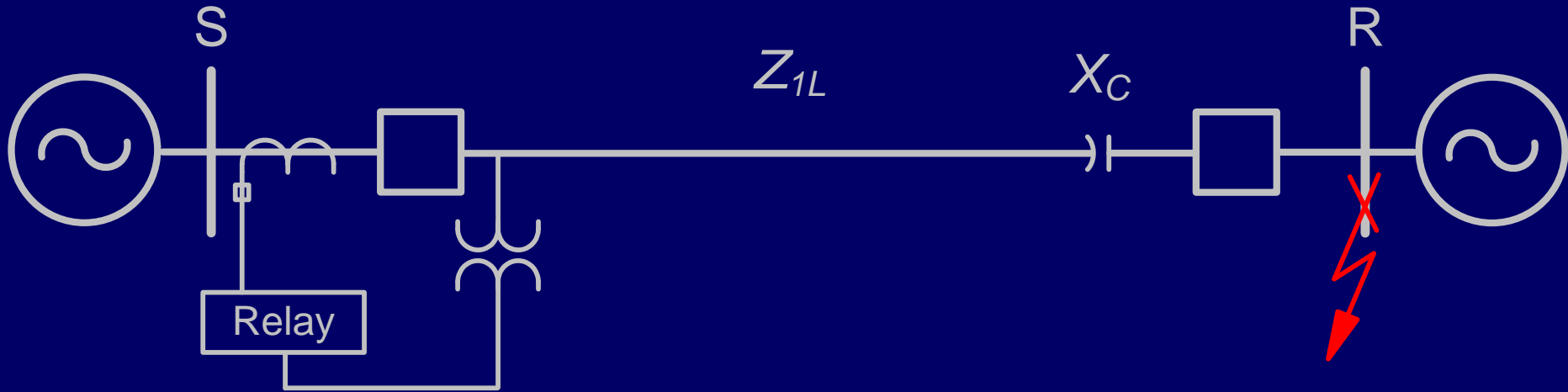

# Voltage Ratio Check Secures Zone 1

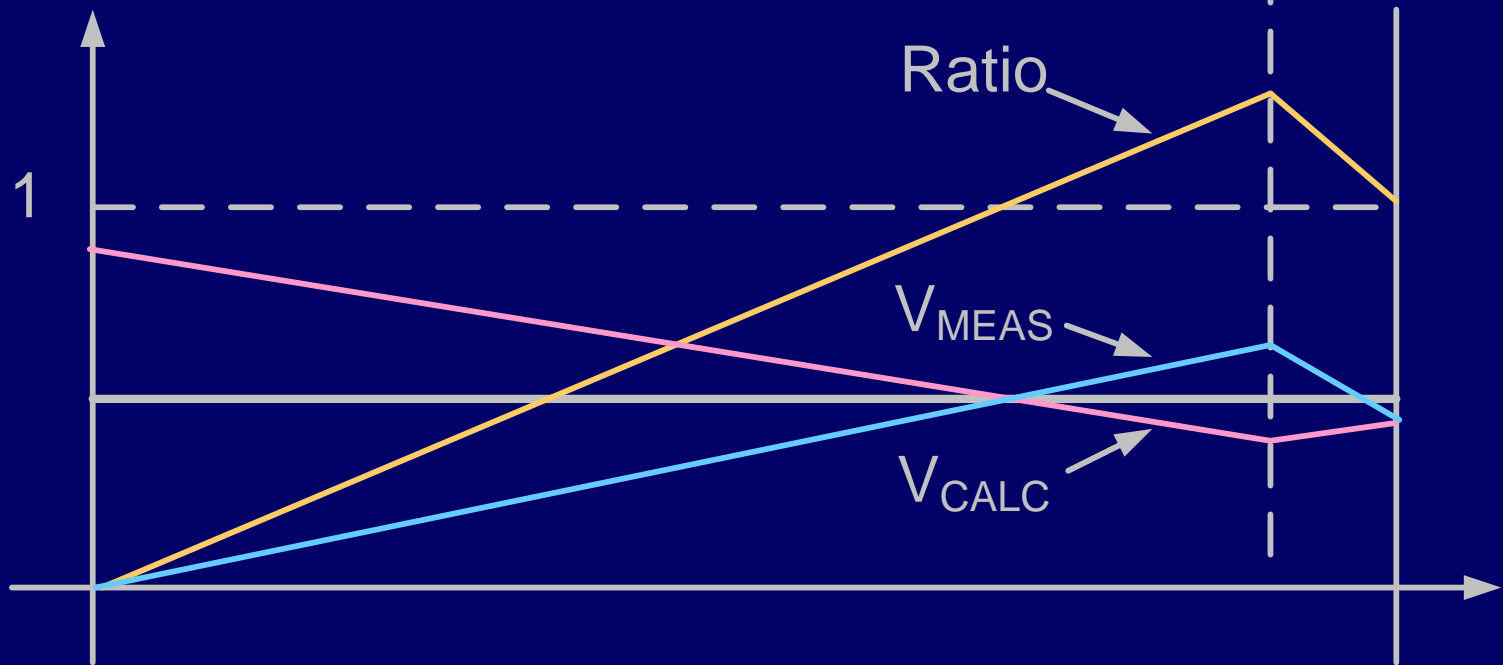
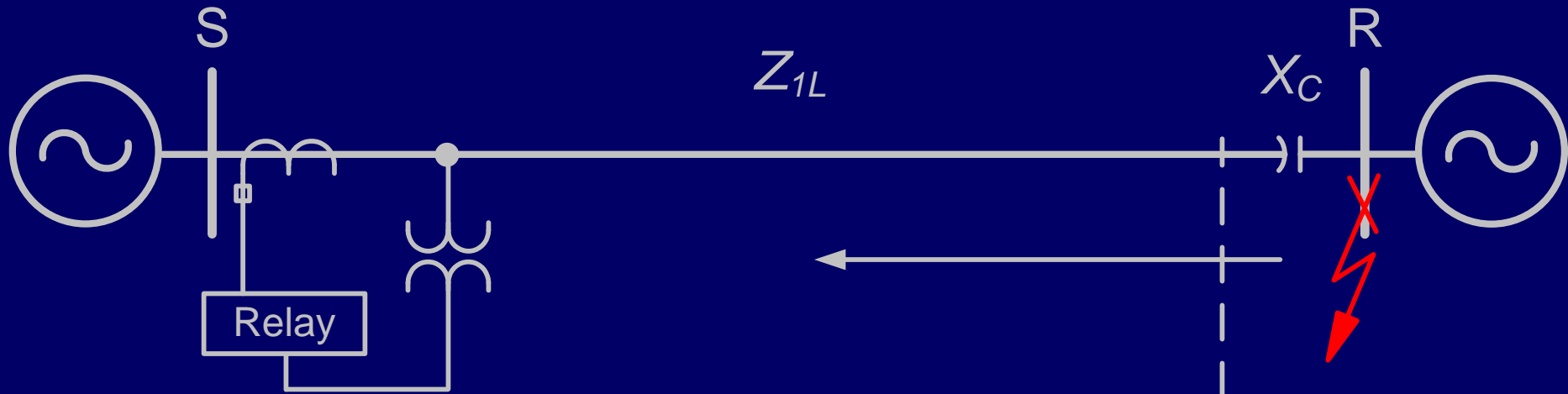

# Infeed Affect Increases Apparent Capacitive Reactance

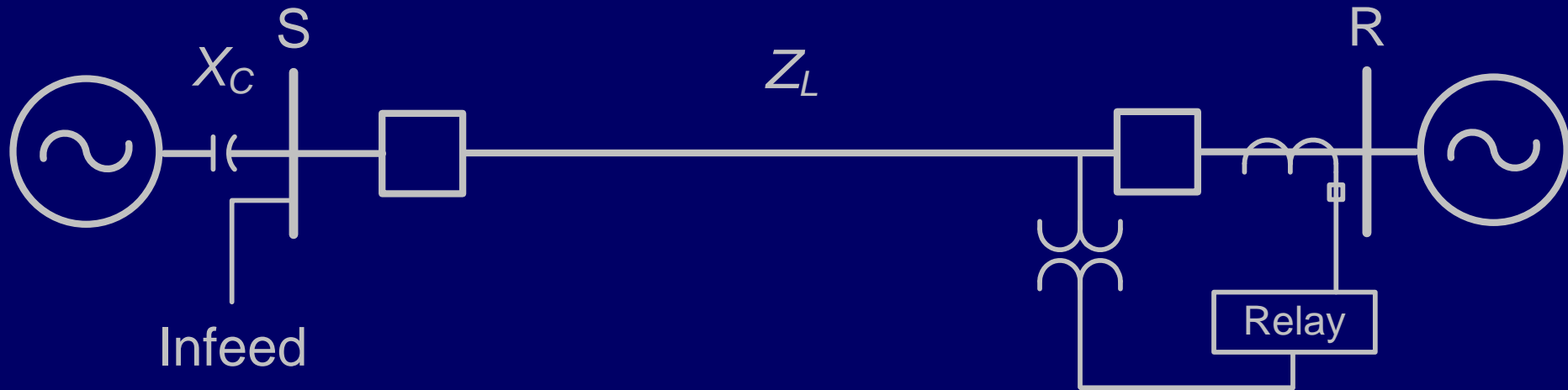

# Alpha-Plane Differential Characteristic

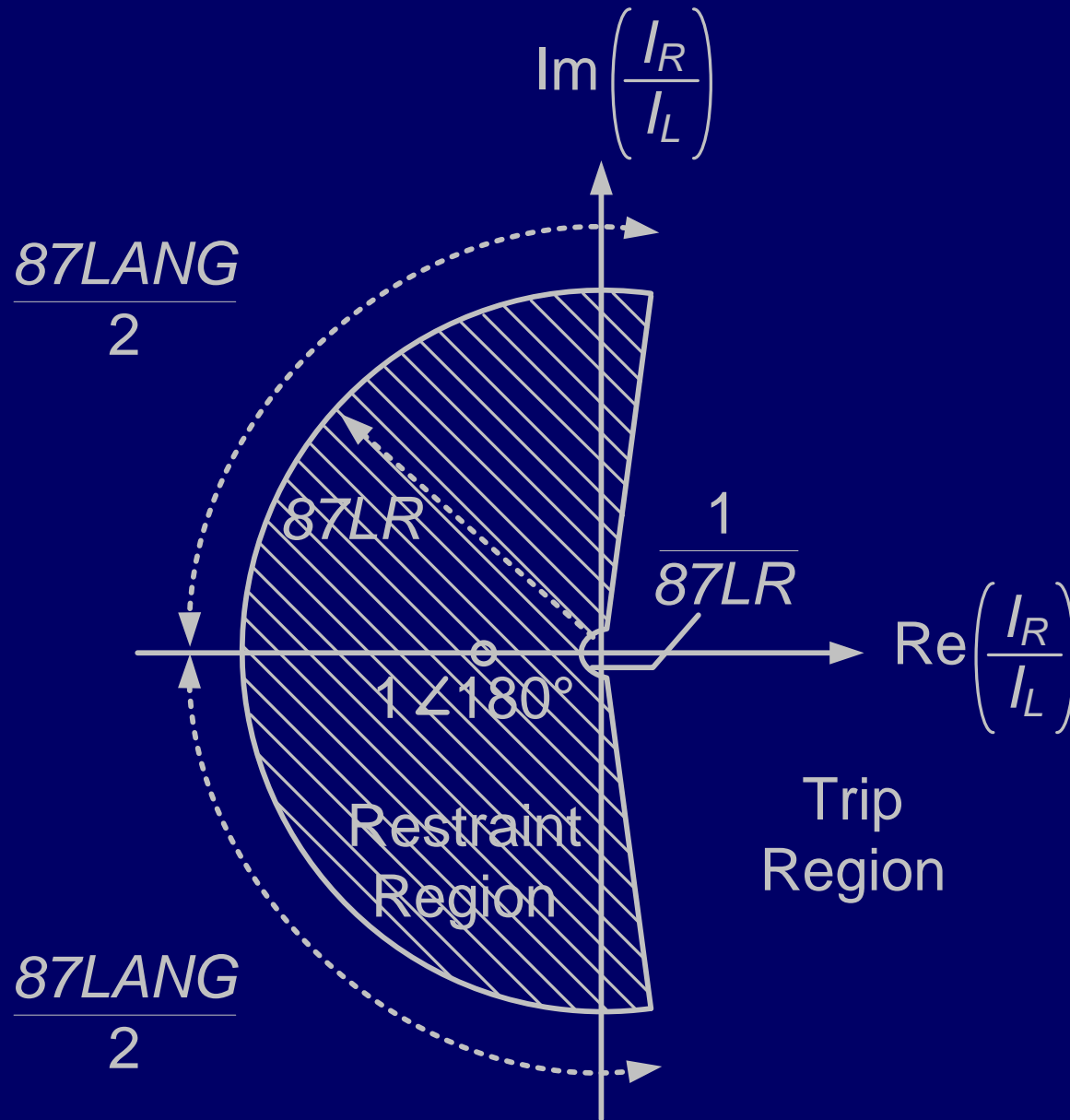

# Differential Element Response to an Internal Fault

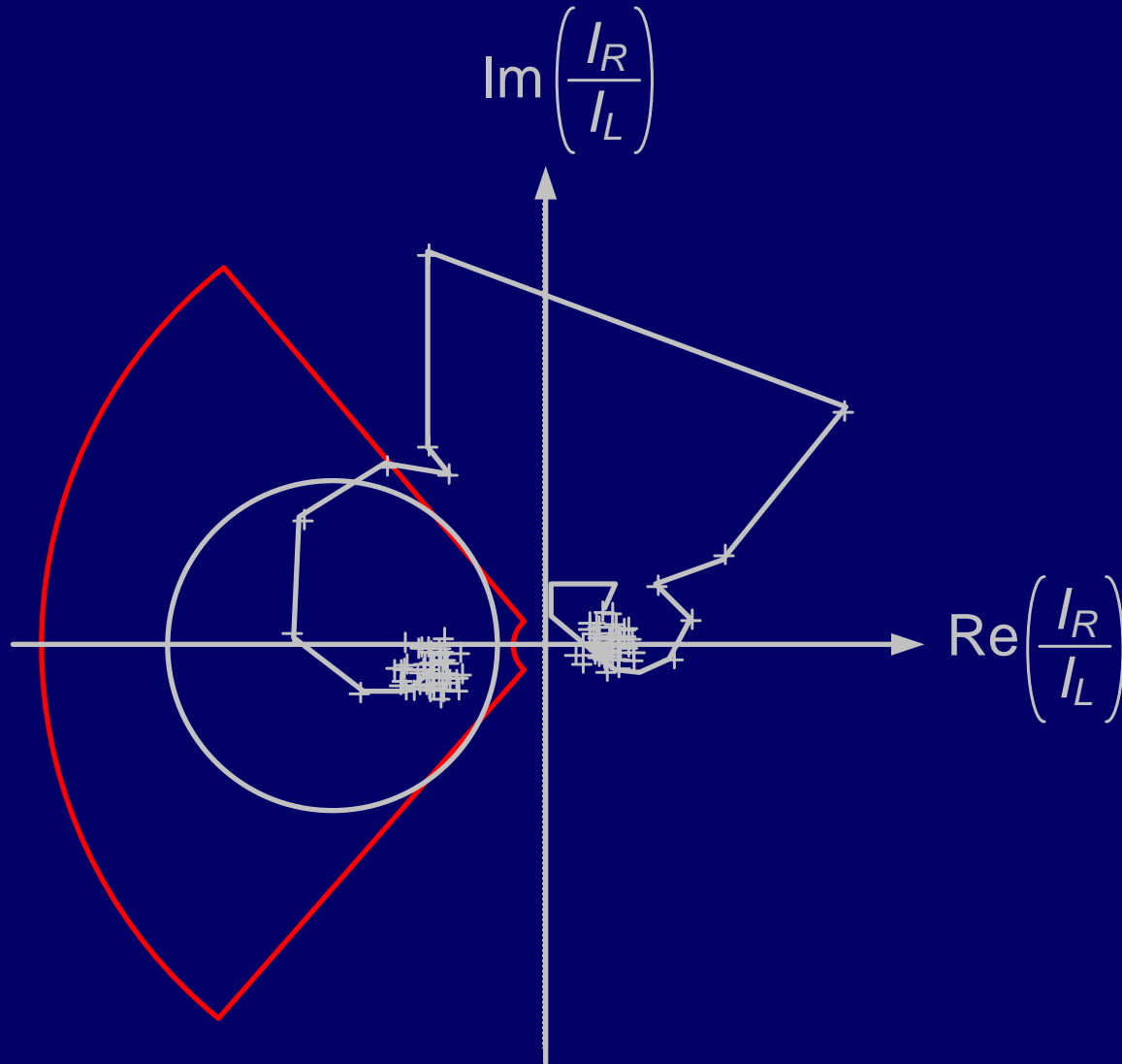

# Analysis of Field Events

- Parallel 500 kV lines with 70% compensation
- Internal fault on 500 kV line
- Internal fault on 345 kV line with bus side PTs

# Voltage Ratio Check – Close-in Fault

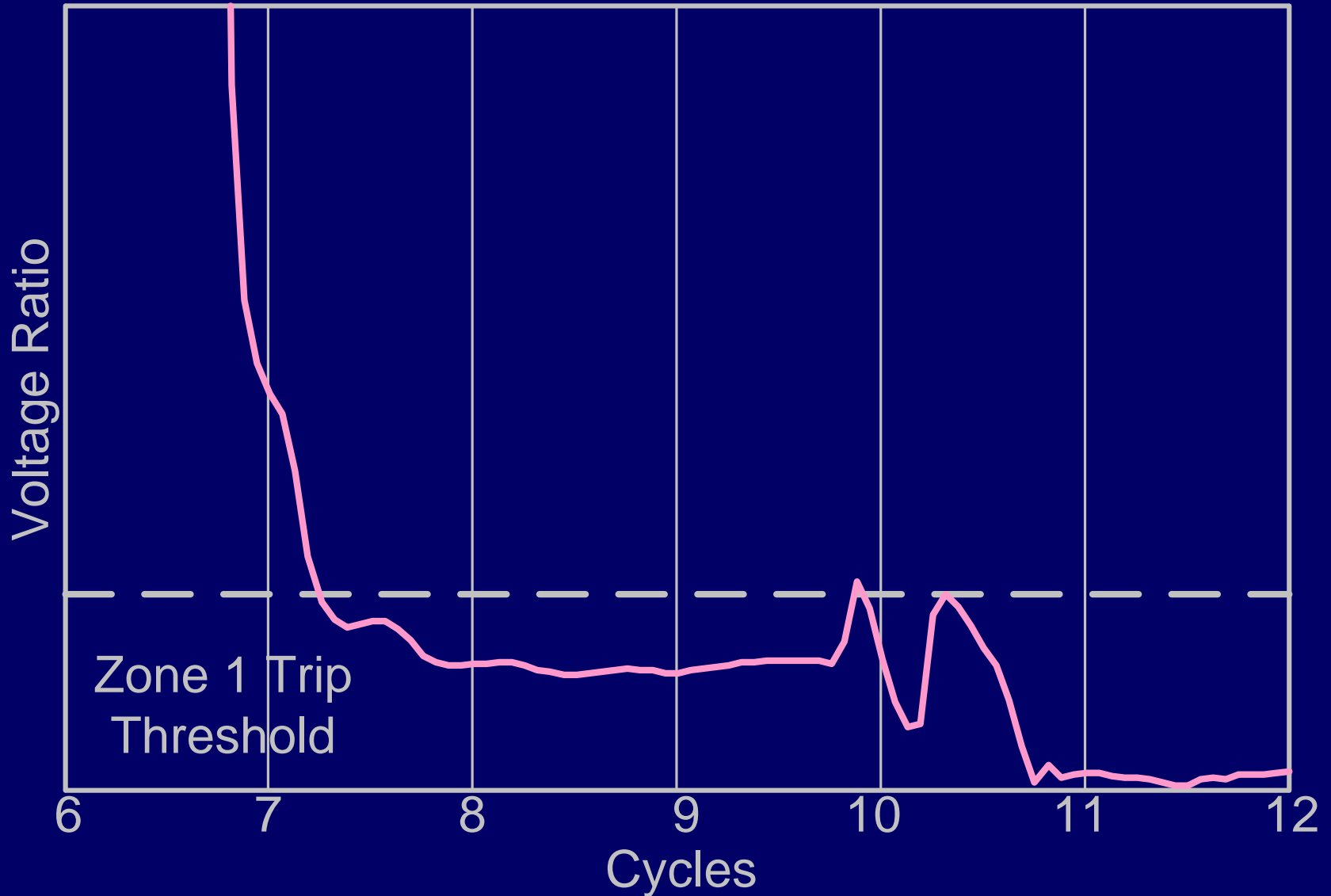

# Voltage Ratio Check – Parallel Line

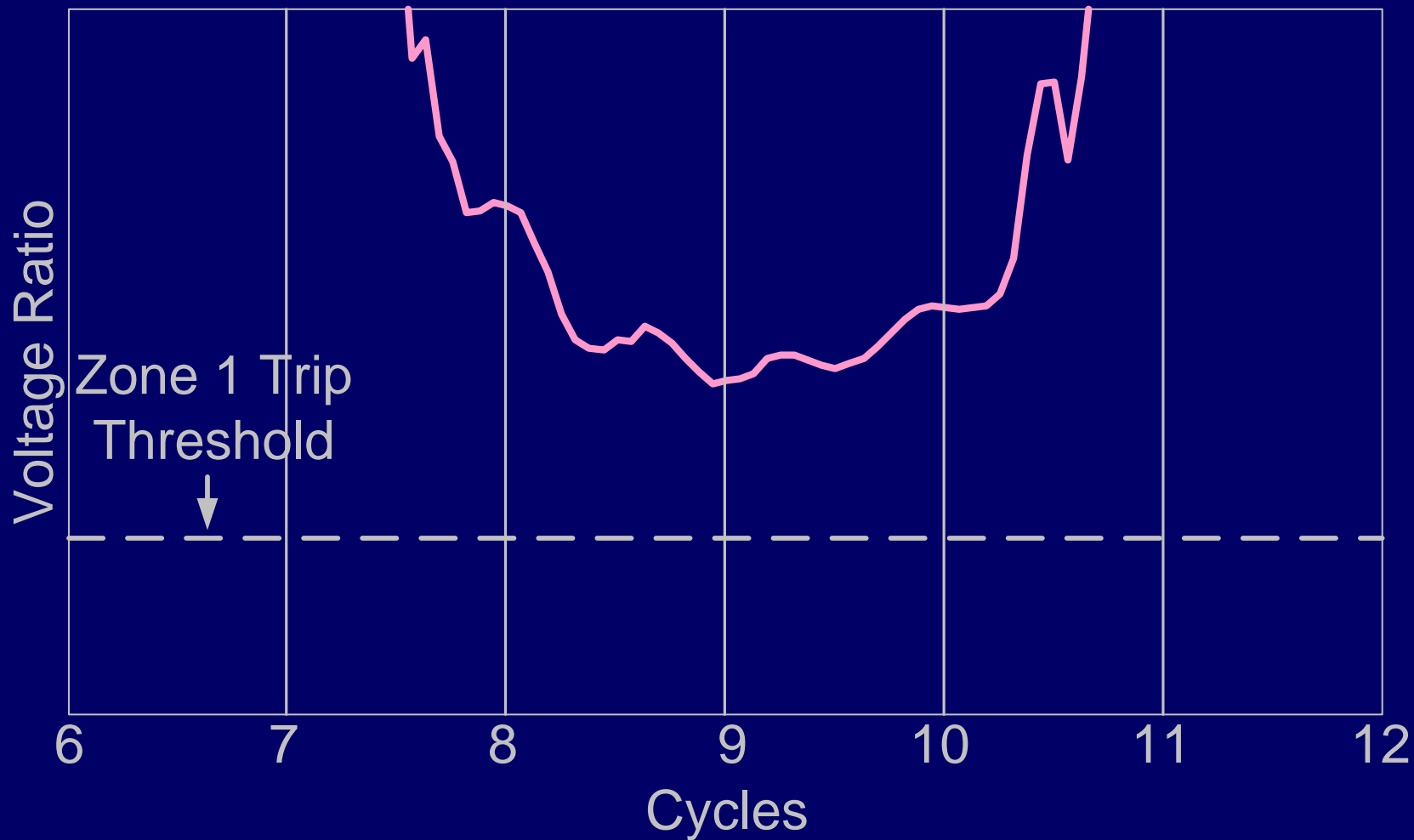

# Internal Fault – Zone 2

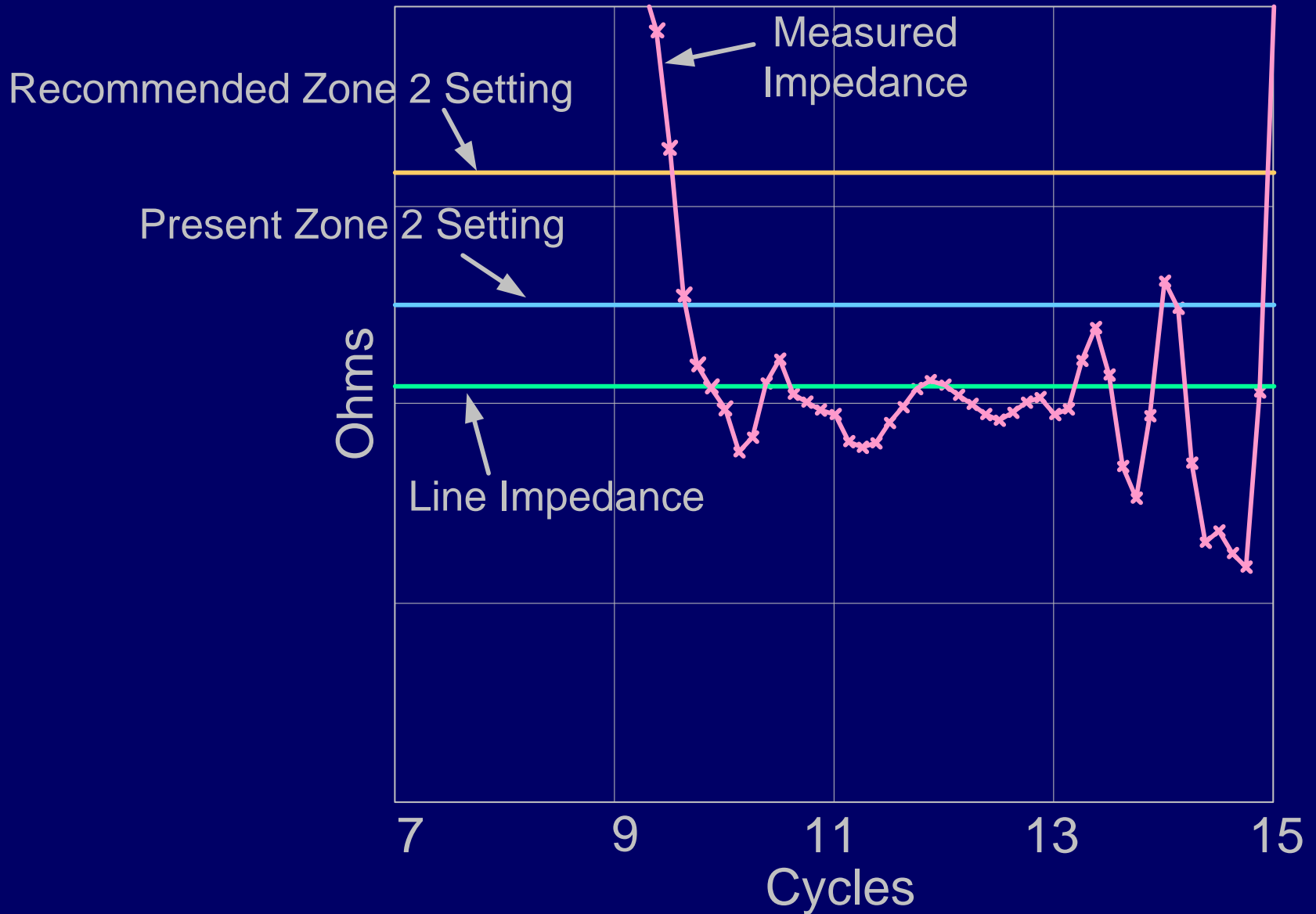

# Voltage Inversion – Phase Voltage



# Voltage Inversion – V1

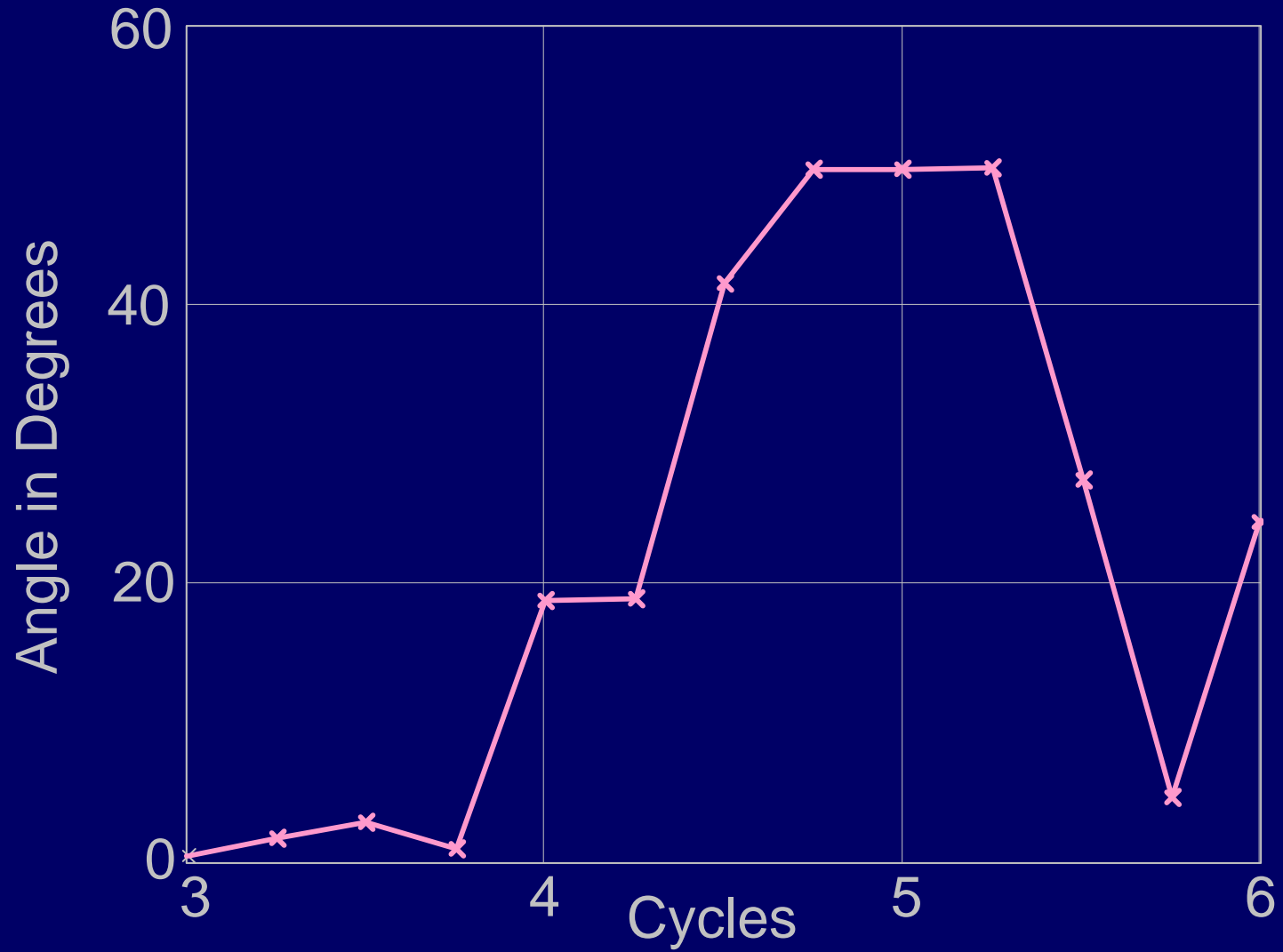

# Conclusions

- Memory polarization and directional element offset address voltage inversion
- Line current differential elements are more tolerant to current inversion

# Conclusions

- Low frequency oscillations can cause overreach and underreach of distance elements
- Transient simulation and testing is strongly recommended