

Design and Testing of a System to Classify Faults for a Generation-Shedding RAS

Kyle Baskin
Formerly of PacifiCorp

and

Michael Thompson and Larry Lawhead
Schweitzer Engineering Laboratories, Inc.

Jim Bridger Power Plant

- 2.2 GW installed capacity
- Power transmitted west from Wyoming to Southern Idaho
 - ◆ Three 345 kV lines
 - ◆ 200 miles long
 - ◆ Series compensated

Stability Limited

- Capacity restricted to 60% without remedial action scheme (RAS)
- Generation-shedding RAS is required

Bridger West Transmission System

LEGEND:

- 345 kV
- ± 500 kV DC
- 500 kV
- 230 kV
- 115-161 kV

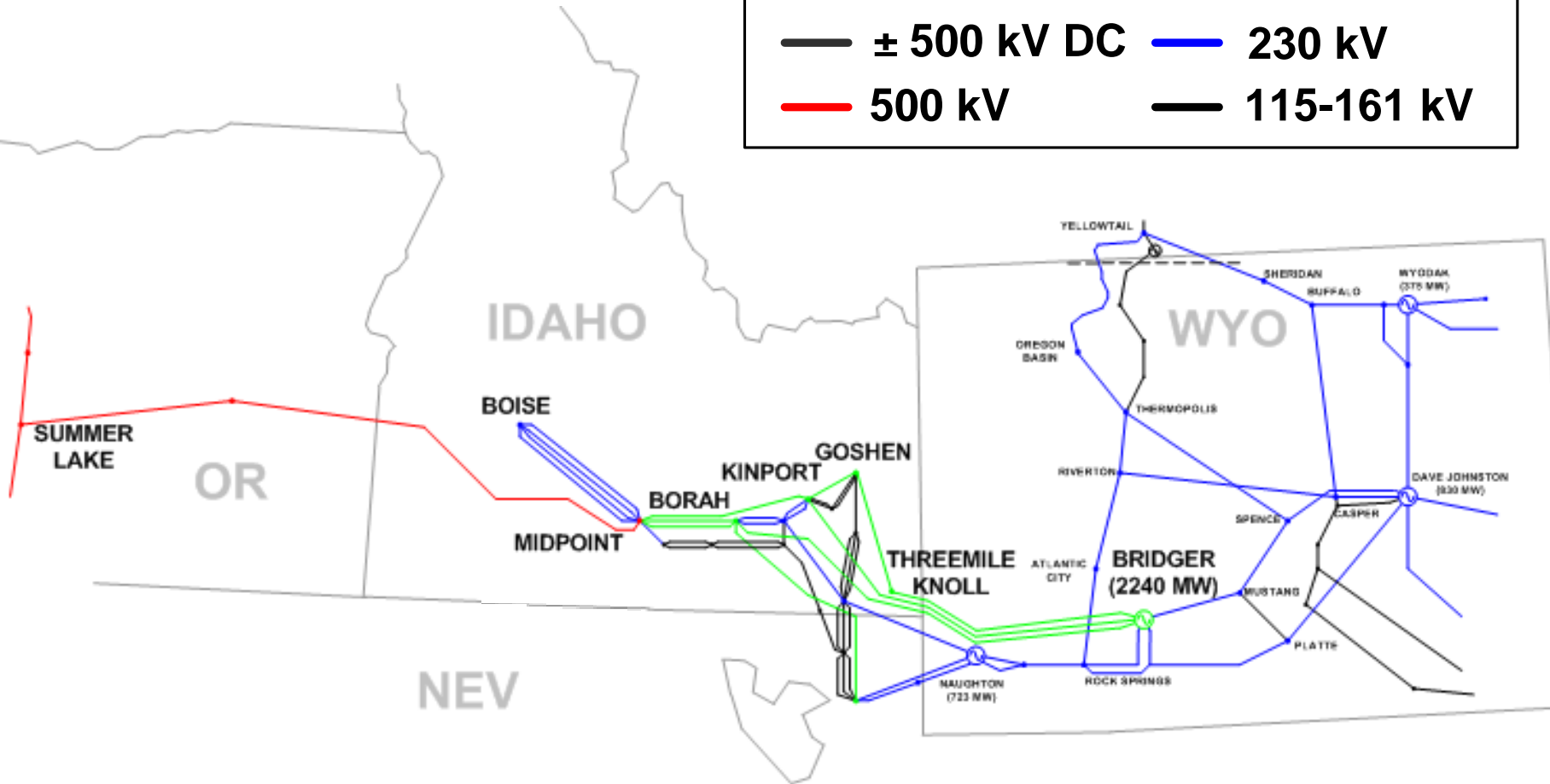

RAS Modernization

- Monitors
 - ◆ Six lines
 - ◆ Four generators
 - ◆ Shunt and series capacitors
- Determines optimum level of generation to shed
 - ◆ Current system status
 - ◆ Severity of initiating event

Dynamic Stability Theory

$$P = \left(\frac{E_S \cdot E_R}{X_L} \right) \sin \delta$$

- Power not transmitted accelerates rotors
- Fault severity affects swing
 - ◆ Close-in fault—reduces E_S
 - ◆ More faulted phases—increases X_L

Effect of Fault Type

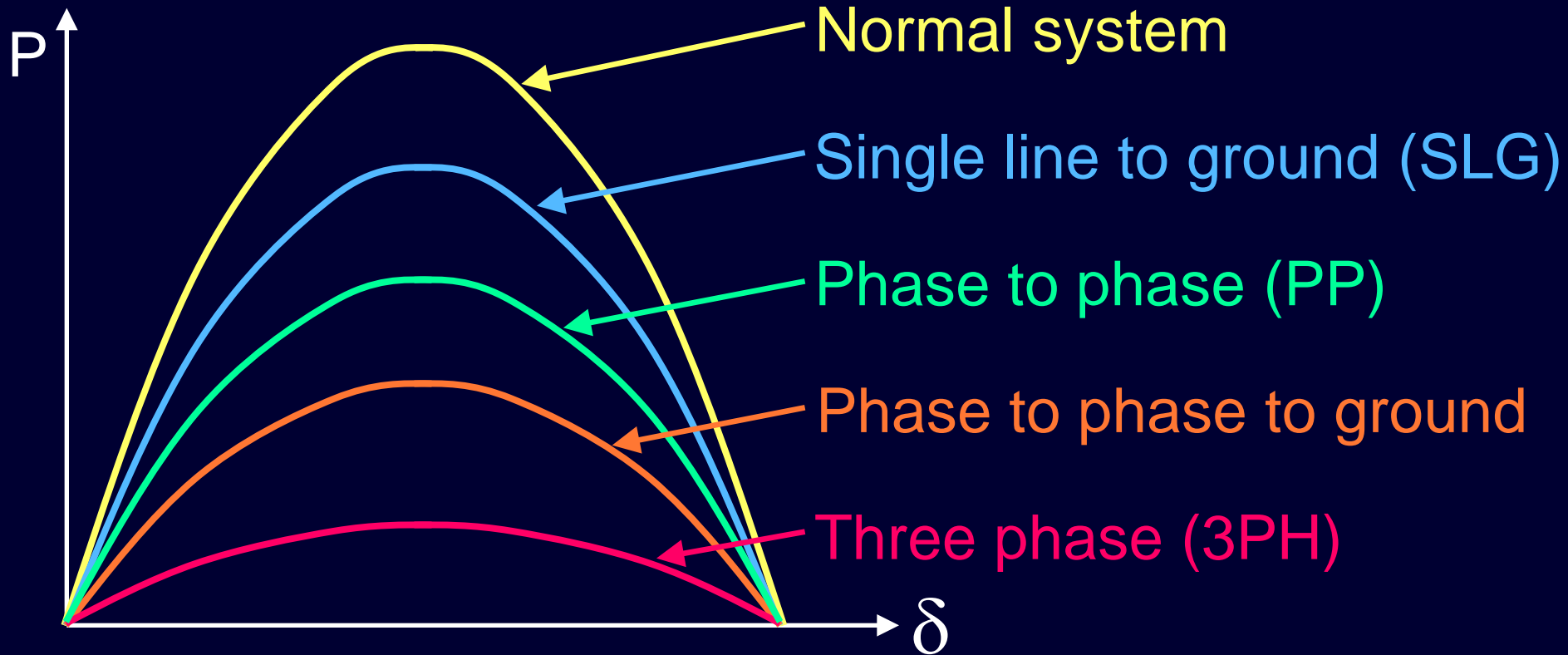
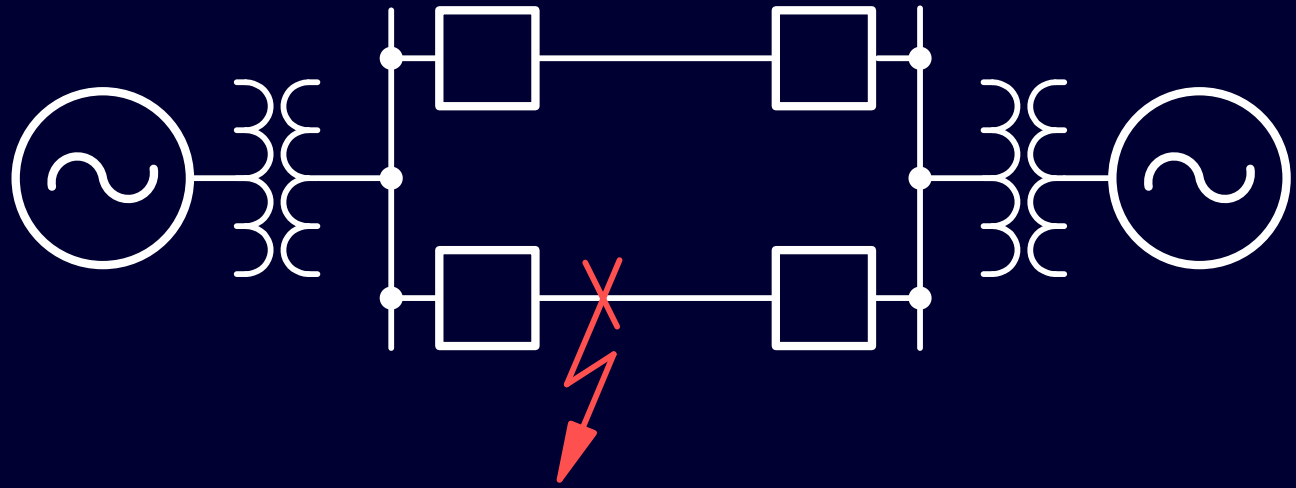

RAS Logic Relay Outputs

- Fault types
 - ◆ SLG
 - ◆ PP and DLG
 - ◆ 3PH
- Severity
 - ◆ Fault within first 25% of line
 - ◆ Fault beyond first 25% of line

RAS Logic Relay Outputs

	Single Line to Ground	Multiphase Unbalanced	Multiphase Balanced
Nonsevere	No output	PP nonsevere	3PH nonsevere
Severe	No output	PP severe	3PH severe

Additional Requirements

- Only one output per event
- Err on the side of most severe classification
- Output in two cycles
- Easy-to-set criteria

Classifying Fault Severity

Two Phase Distance Elements

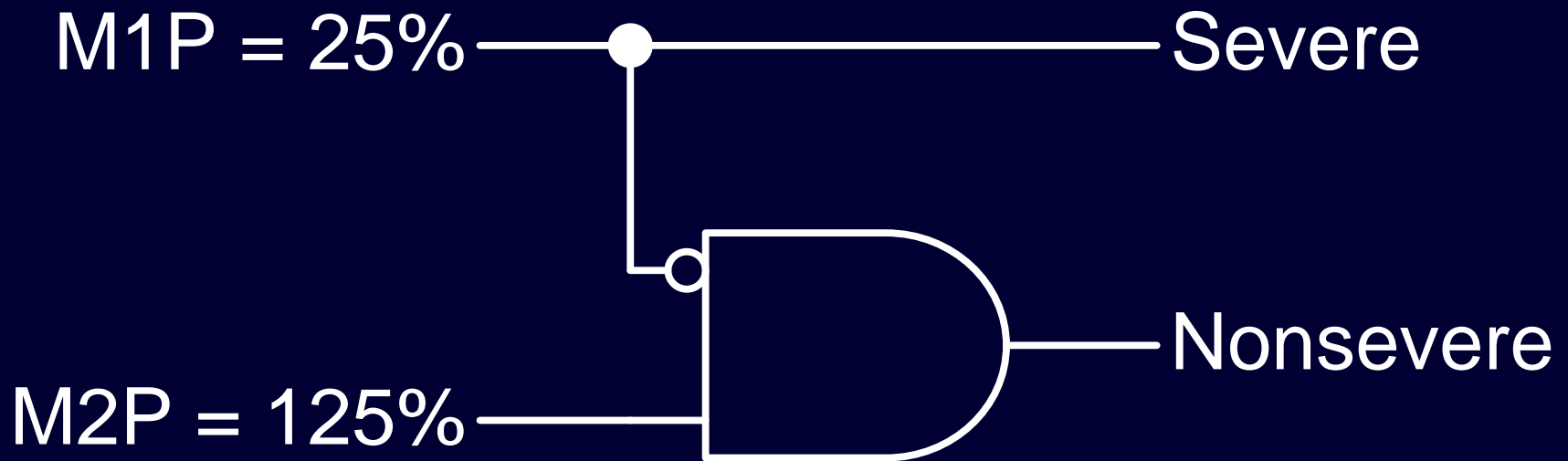

Classifying Fault Severity

- Speed is function of multiple of reach
- Fault at boundary
 - ◆ 100% of Zone 1 reach
 - ◆ 17% of Zone 2 reach
- How long to wait for M1P?

Speed of Distance Elements

- Dominated by filter window
- Subcycle elements use less filtering
- Less filtering = transient overreach
- M1P is two elements in parallel
 - ◆ Full cycle with set reach
 - ◆ High speed with reduced reach

Classifying Fault Severity

- M1P versus M2P timing variability increased
- Solution – use M4P and M5P

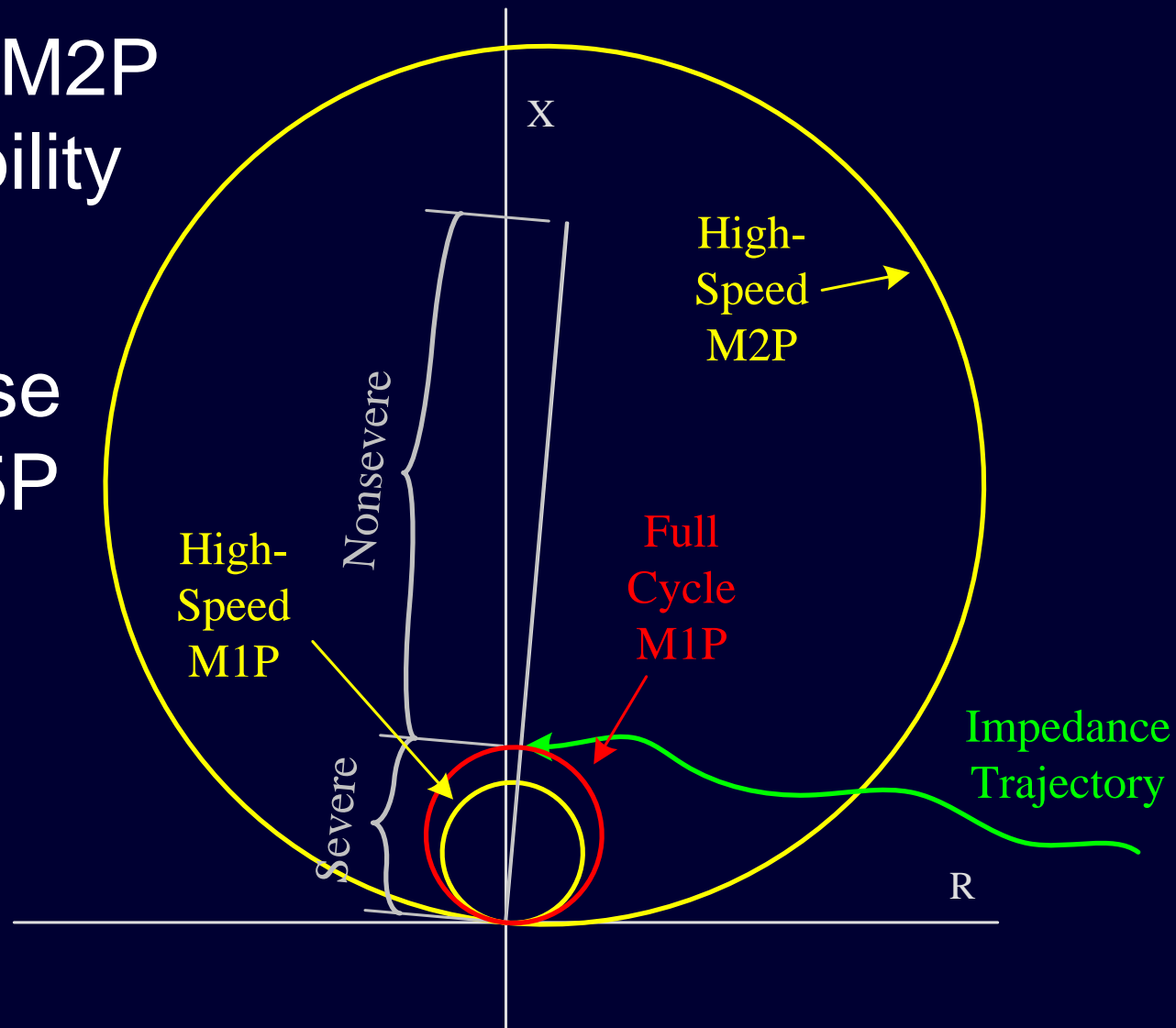

Fault Type Classifications

- Multiphase balanced (3PH)
- Multiphase unbalanced
 - ◆ DLG
 - ◆ PP

Possible Methods

- Faulted phase identification logic
 - ◆ Used for single-pole-trip function
 - ◆ Only runs for faults involving ground
- Phase loop assertion logic
- Negative-sequence current

Phase Loop Assertion Logic

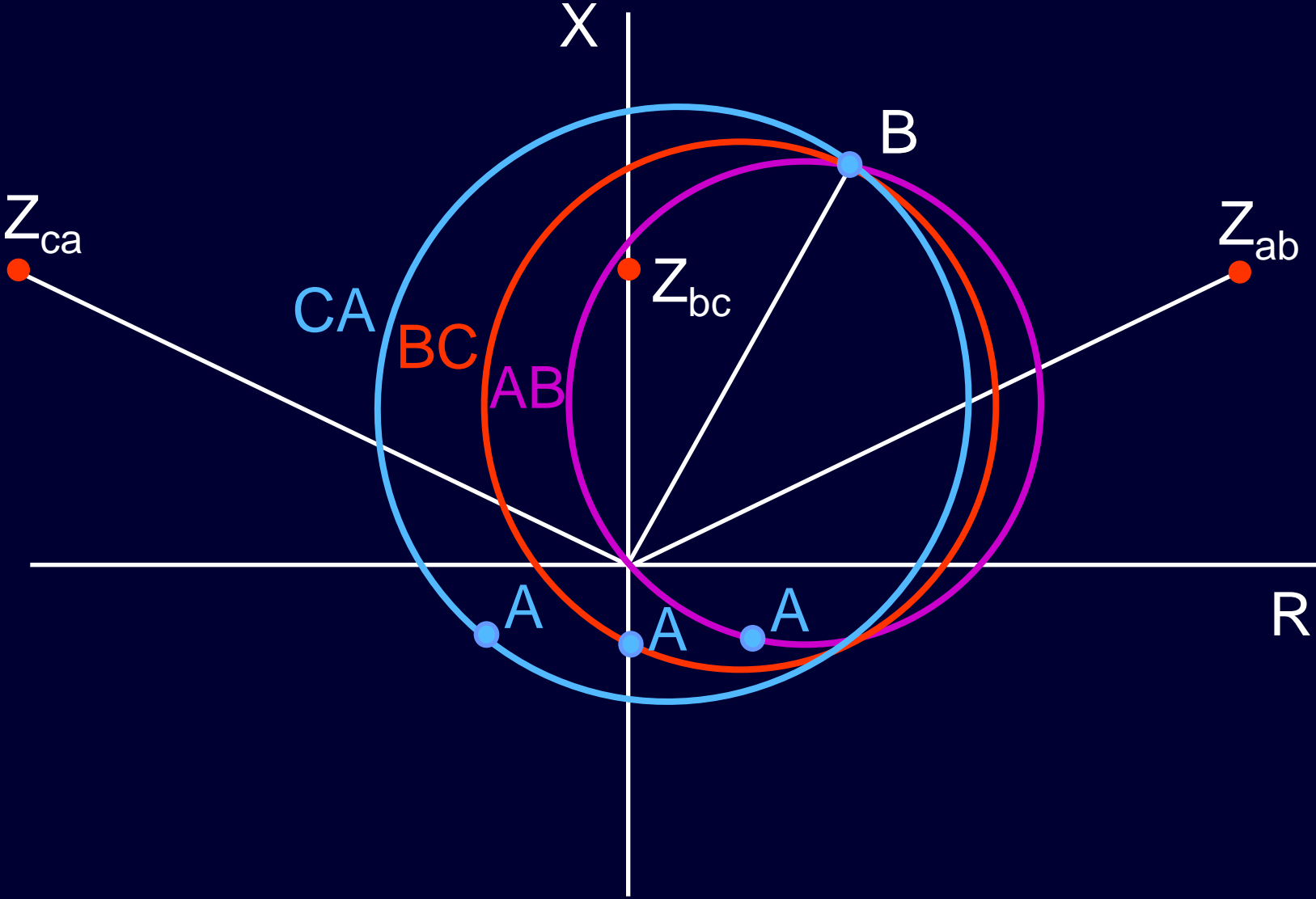

Negative-Sequence Current Natural System Unbalances

- Lines not perfectly transposed
- Series capacitor bypass protection
- a_2 is ratio of I_2/I_1

Negative-Sequence Current

- Filter transient
 - ◆ Finite impulse response (FIR) filter has err during transition between power system states
 - ◆ Err can last more than one cycle
- 50Q element
 - ◆ Magnitude check only
 - ◆ No acceptable setting

I1 and I2 for Close-In 3PH Fault

I1/I2

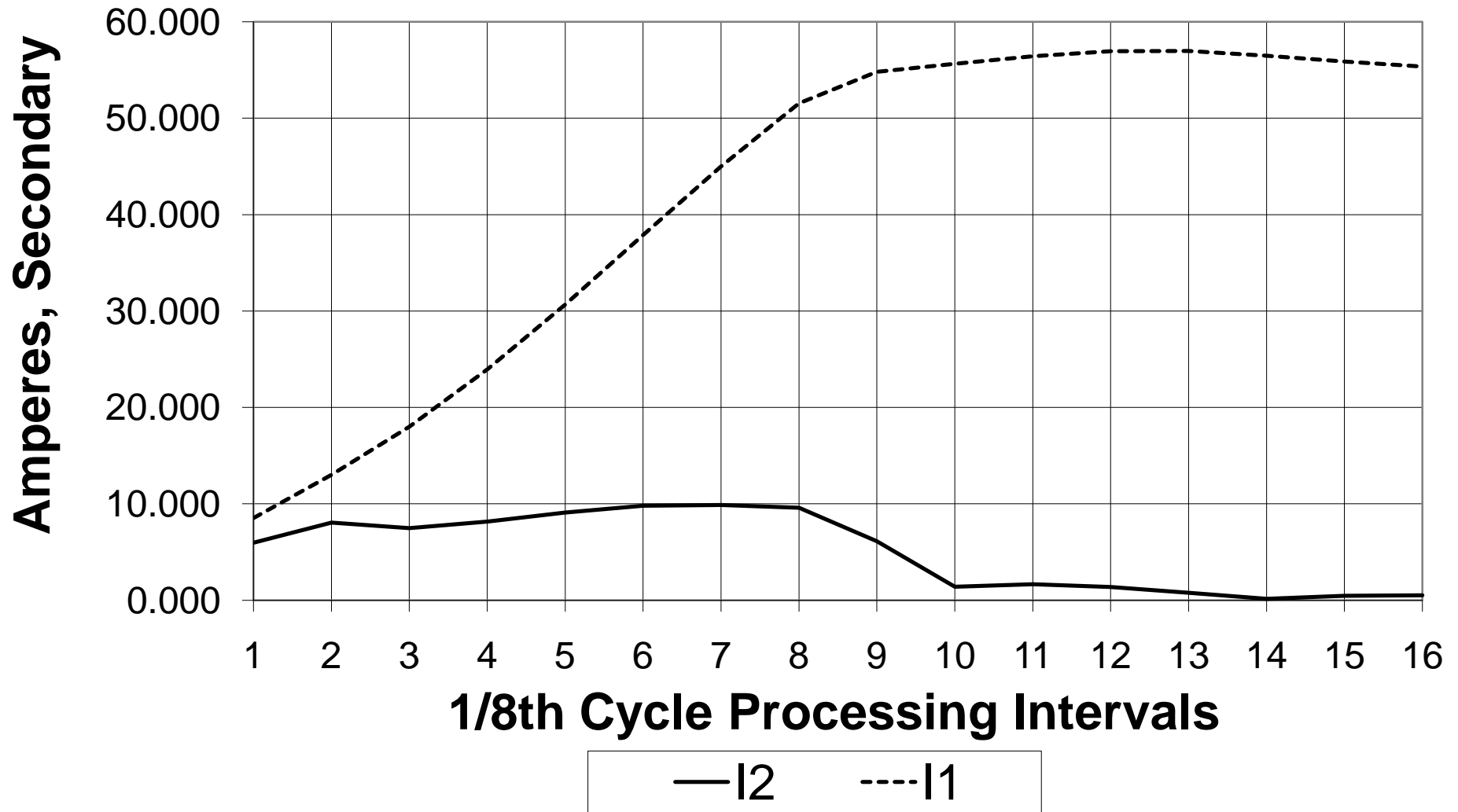

New Method for Classifying Fault Type

- Borrows concept from variable percentage differential element
- Ratio of operate to restraint
 - ◆ Operate = I_2
 - ◆ Restraint = I_1
- Variable percentage
 - ◆ Higher ratio for close-in fault
 - ◆ Lower ratio for remote fault

Variable Percentage a2 Ratio Comparator

Slope

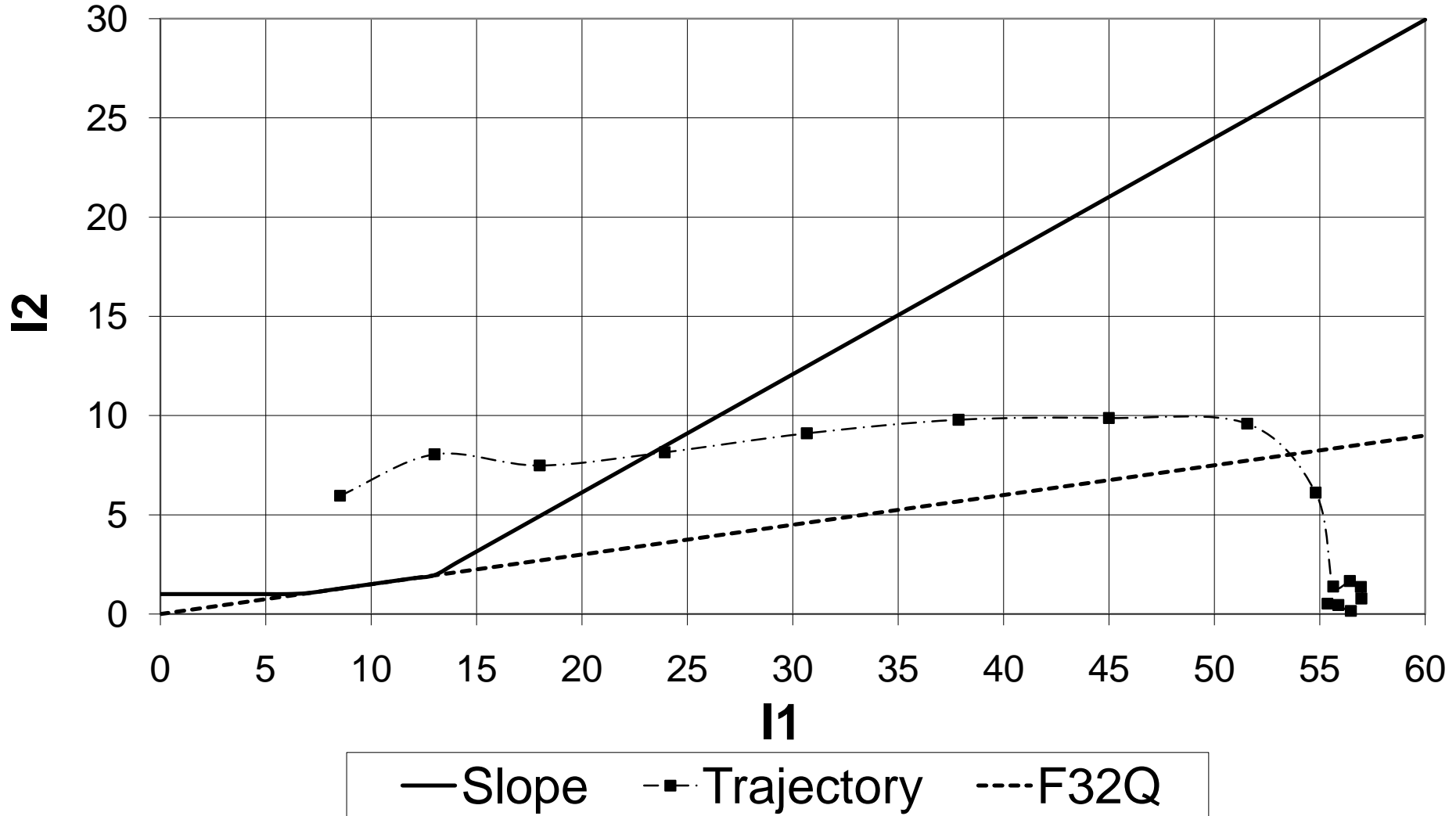

Settings Criteria

- PP fault a2 ratio $\approx 100\%$
- DLG fault is boundary case for a2 ratio
- Worst a2 ratio at Bridger $\approx 50\%$

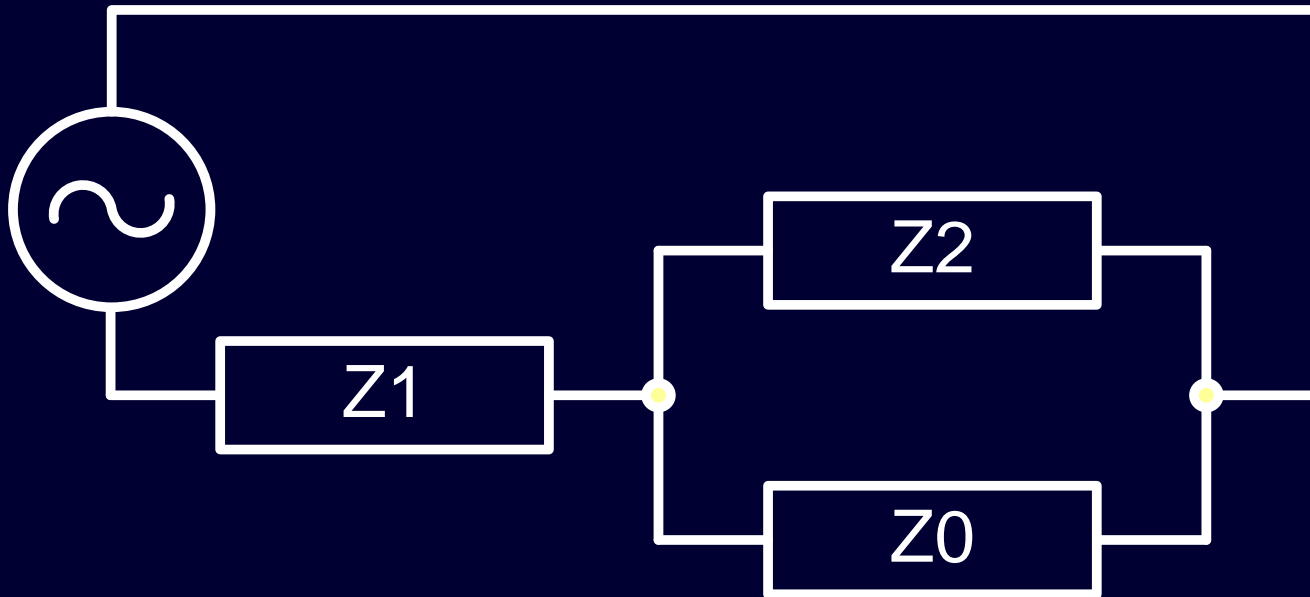

Plot for Close-In DLG Fault

Slope

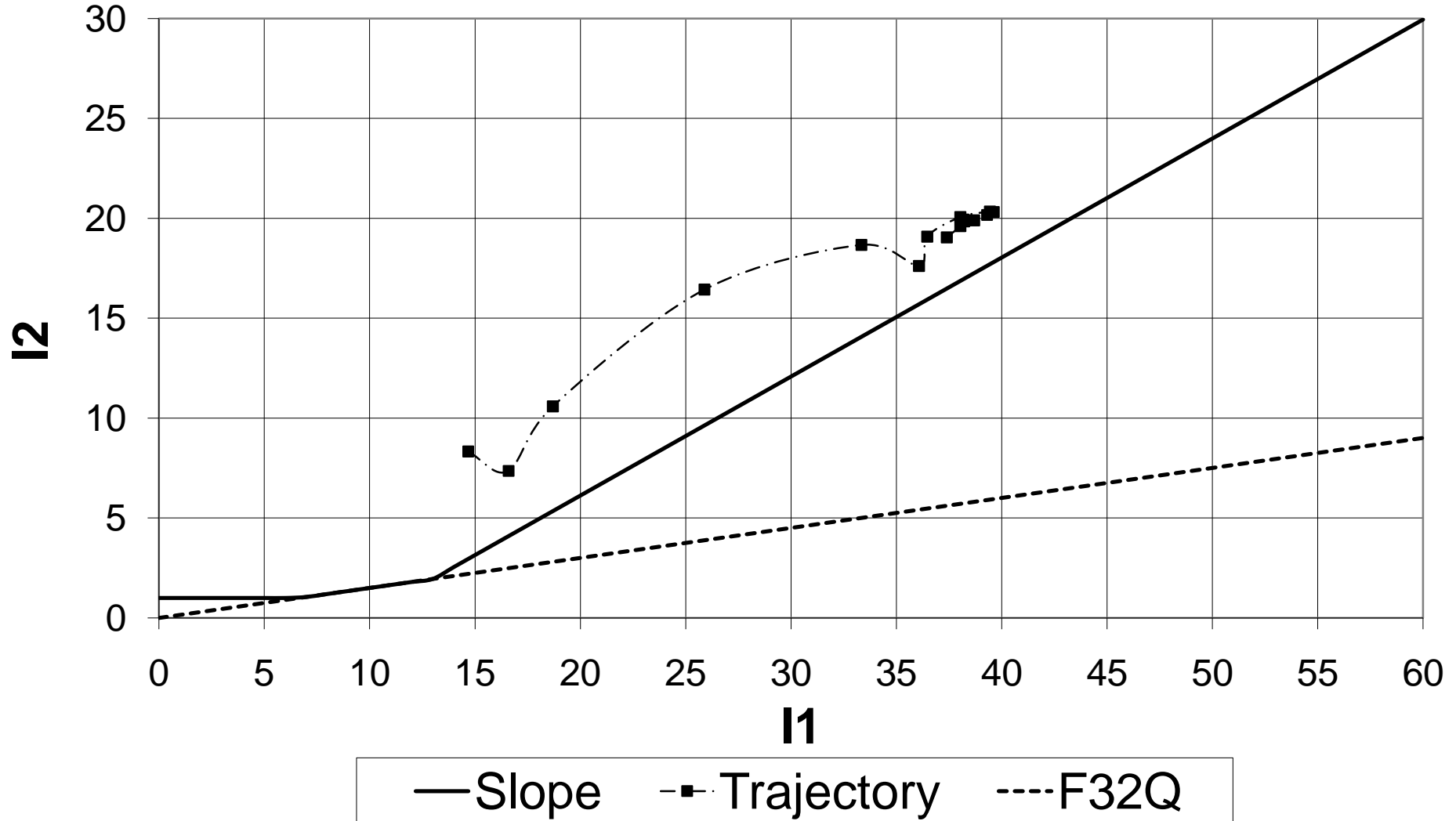

Settings Process

- Step 1. Obtain I_2 for close-in and remote DLG
- Step 2. Choose a_2 ratio for close-in case and calculate I_2, I_1 coordinate point
- Step 3. Calculate I_2, I_1 coordinate point for remote DLG at fixed a_2 ratio setting

Settings Process

- Step 4. Create line in I2/I1 plane that goes through points obtained in Steps 2 and 3
- Step 5. Calculate $y = mx + b$ equation coefficients to describe line created in Step 4

Low Transient I2 Case

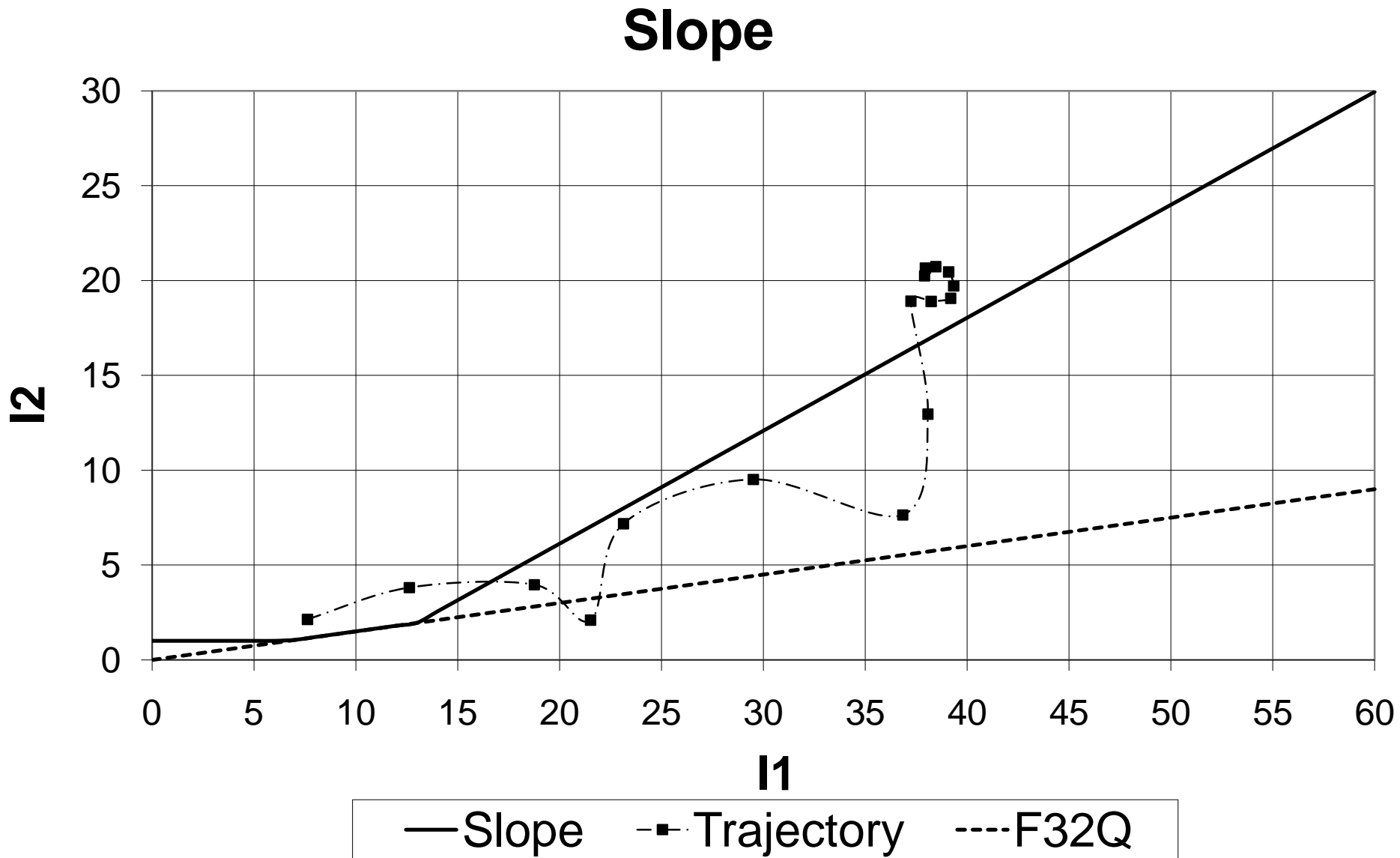

Validation

- Real Time Digital Simulator (RTDS®)
- Automatic scripting
- 1,650 shots per line
- 14 hours to complete each line's batch test

Batch Test for Each Line

- Five load flow cases
- Fault locations
 - ◆ 0% to 40% of line at 5% increments
 - ◆ In front of and beyond remote series capacitor
- All ten fault types
- Three point-on-wave shots

Final Results

Bridger to Threemile Knoll Line

- 43 of 1,650 shots misclassified as severe
- 1 of 1,650 shots misclassified as 3PH
- All errors were on conservative side
- Time-delay setting of $\frac{5}{8}$ of a cycle provided good results

Summary

- Bridger requires RAS to operate at capacity
- Generation shedding can be optimized
- Obtained better understanding of transient response of relay elements
 - ◆ Faulted phase identification logic
 - ◆ Distance elements
 - ◆ Digital filtering algorithms

Conclusions

- I2 best indicator of unbalanced fault types
 - ◆ 50Q could not be used
 - ◆ Fixed a2 ratio check unsatisfactory
 - ◆ Variable percentage a2 ratio check provided best results
- Required simple settings criteria
 - ◆ Review symmetrical component theory
 - ◆ RTDS validated settings criteria and optimized timing setting

Conclusions

- Platform allowed engineers to think outside the box
 - ◆ Custom mathematical calculations
 - ◆ Processed at protection speeds
- RTDS testing provided high confidence in new algorithm